



INSTALLATION, SERVICE AND MAINTENANCE INSTRUCTIONS

RF PUMP



INOXPA, S.A.

c/Telers, 54 Aptdo. 174

E-17820 Banyoles

Girona (Spain)

Tel. : (34) 972 - 57 52 00

Fax. : (34) 972 - 57 55 02

Email: inoxpa@inoxpa.com

www.inoxpa.com



Original Manual

01.650.30.00EN

(G) 2015/09



EC Declaration of Conformity

The manufacturer: **INOXPA, S.A.**
c/ Telers, 57
17820 Banyoles (Girona), Spain

herewith declares that the machine:

RF Flexible impeller pump

with the serial number: _____

conforms to the relevant provisions of the following directives:

Machinery Directive 2006/42/EC (RD 1644/2008)
Low voltage Directive 2006/95/EC
Electromagnetic Compatibility Directive 2004/108/EC

Applicable harmonised Standards:

UNE-EN ISO 12100:2012
UNE-EN 809:1999+A1:2010

Identification of the person empowered to draw up the Declaration on behalf of the manufacturer, and qualified to compile the technical file established by the Community:

Banyoles, 23 September 2015

David Reyer Brunet
Technical Office Manager

1. Safety

1.1. INSTRUCTIONS MANUAL

This manual contains information about the reception, installation, operation, assembly, disassembly and maintenance of the RF pump.

The information provided in this Instructions Manual is based on updated facts. INOXPA reserves the right to modify this Instruction Manual without prior notice.

1.2. START-UP INSTRUCTIONS

This Instructions Manual contains vital and useful information for properly operating and maintaining your pump.

Read carefully these instructions before starting up the pump; become familiar with the operation and use of your pump and follow the instructions closely. It is very important that a copy of these Instructions is kept in a set place near the plant.

1.3. SAFETY

1.3.1. Warning signs



General danger of injury



Danger of injuries caused by the rotary parts of the equipment.



Electrical hazard



Danger! Caustics or etching materials



Danger! Suspended load



Danger of equipment malfunction



Compulsory requirement to ensure safety at work



Use of goggles is compulsory

1.4. GENERAL SAFETY INSTRUCTIONS



Read carefully this Instructions Manual before installing the pump and starting it up. If in doubt, contact INOXPA.

1.4.1. During installation



Always observe the *Technical Specification* given in Chapter 8.

Never start up the pump before it has been connected to the piping.

Do not start up the pump before it has been installed.

Check that the motor specifications are the required ones, especially when working under conditions that involve the risk of explosion.



During the installation of the pump, all the electrical work must be carried out by an authorized operative.

1.4.2. During operation



Always observe the *Technical Specification* given in Chapter 8. NEVER exceed the limit of the specified values.

NEVER touch the pump or the pipes during operation when the pump is being used to decant hot fluids or when it is being cleaned.



The pump contains moving parts. Never introduce your fingers into the pump while the pump is in operation.



NEVER operate the pump with the inlet and discharge valves closed.

NEVER clean the electrical motor with water. The standard protection of the motor is IP-55: Protection against dust and spraying water.

1.4.3. During maintenance



Always observe the *Technical Specification* given in Chapter 8.

NEVER disassemble the pump before the pipes have been emptied. Remember that some of the fluid will always remain in the pump casing (when no drainage is provided). Note that the pumped fluid may be dangerous or very hot. Please refer to the regulations applicable in the respective country.

Do not leave detached parts on the floor.



ALWAYS disconnect the pump from the power before beginning the maintenance. Remove the fuses and disconnect the cables from the motor terminals.

All the electrical work must be carried out by an authorized operative.

1.4.4. Compliance with the instructions

Any failure to comply with the instructions might entail risks to the operators, the environment and the equipment, and result in the loss of the right to claim for damages.

Such non-compliance might entail the following risks:

- Failure of important functions of the equipment / plant.
- Failure of specific maintenance and repair procedures.
- Threat of electrical, mechanical and chemical risks.
- Environmental risks caused by the release of substances.

1.4.5. Warranty

Any warranty provided shall immediately and *ipso jure* become void, and INOXPA shall be indemnified against any product liability claim from third parties, if:

- the service and maintenance work was not carried out in accordance to the service instructions, or the repair work has not been carried out by our personnel or it has been carried without our written authorization;
- our materials have been changed without prior written authorization;
- the parts or lubricants used are not original INOXPA parts and products;
- the materials were used improperly or carelessly, or not in accordance to these instructions and their intended use;
- pump parts were damaged by strong pressure for lack of a safety valve.

The General Delivery Terms already furnished to you also apply.



No change can be made to the equipment without prior discussion with the manufacturer. For your safety, please use original spare parts and accessories.

The use of other parts will release the manufacturer from any liability.

The service terms can only be changed with prior written authorisation from INOXPA.

When in doubt, or if you would like more detailed information on specific matters (adjustment, assembly, disassembly, etc.), please do not hesitate to contact us.

2. Table of contents

1. Safety	
1.1. Instructions manual.....	3
1.2. Start-up instructions.....	3
1.3. Safety.....	3
1.4. General safety instructions.....	3
2. Table of contents	
3. General information	
3.1. Description.....	6
3.2. Operating principle.....	6
3.3. Range of application.....	6
4. Installation	
4.1. Reception of the pump.....	8
4.2. Handling and storage.....	8
4.3. Location.....	9
4.4. Pipes.....	9
4.5. Electric wiring.....	9
5. Start-up	
5.1. Start-up.....	10
6. Operating problems	
7. Maintenance	
7.1. General.....	12
7.2. Storage.....	12
7.3. Cleaning.....	12
7.4. Disassembly / Assembly of the pump.....	13
8. Technical specifications	
8.1. Technical specifications.....	16
8.2. Weights.....	17
8.3. Bearings maintenance.....	17
8.4. RF pump dimensions (monoblock).....	18
8.5. RF pump dimensions (bareshaft).....	18
8.6. RF pump dimensions (bareshaft with base plate).....	19
8.7. RF pump.....	20
8.8. RF pump (monoblock).....	21
8.9. Parts list RF.....	21
8.10. RF pump (bareshaft).....	22
8.11. Parts list RF (bareshaft).....	22
8.12. Sealing options.....	23

3. General information

3.1. DESCRIPTION

Flexible-impeller pumps are part of INOXPA's rotary pumps range. Their basic structure consists in a microfusion casing manufactured in AISI 316L and an rubber impeller. The other parts in contact with pumped material are also made of AISI 316L. The pumps of the RF series are available both in monoblock version with direct motor at 1500 rpm and in bareshaft configuration; optionally, they can also be supplied mounted on a stainless-steel or iron trolley. The standard sealing is mechanical seal in graphite / ceramic with EPDM gaskets. The standard connections are DN 11851 adaptors. The design of the RF pumps makes them suitable for handling both low- and high-viscosity fluids, especially those containing solid particles, air, o gases in general. It should be noted that these pumps are self-priming and reversible.

This equipment is suitable for his use in food process.

3.2. OPERATING PRINCIPLE

The operation of the pump can be seen in the following figure:

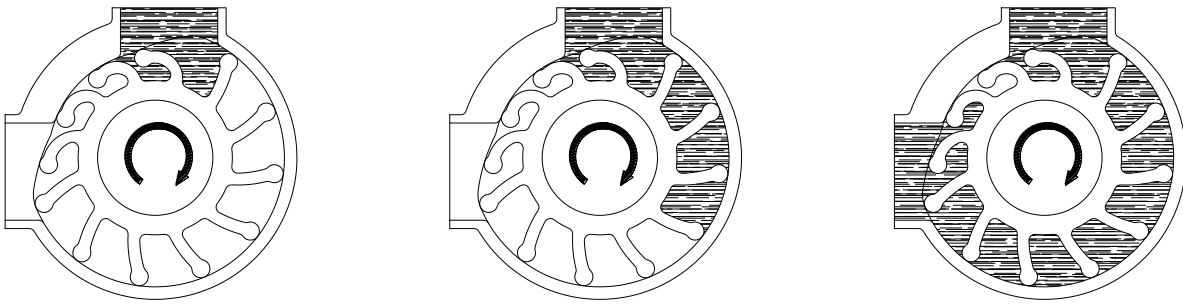

- The special contour of the casing makes the volume of the cavities formed between the casing and the blades increase progressively. Thus, the fluid is forced to flow into the casing.
- The continuous rotation of the impeller transports the chambers filled with fluid from the suction side to the discharge nozzle.
- In the discharge area, the volume of the cavities decreases smoothly, thereby expelling the fluid into the facility.
- From this principle of operation, it can be seen that these are reversible pumps; i.e.. by changing the direction of rotation of the impeller, the direction of pumping can be inverted.

3.3. RANGE OF APPLICATION

900 r.p.m.

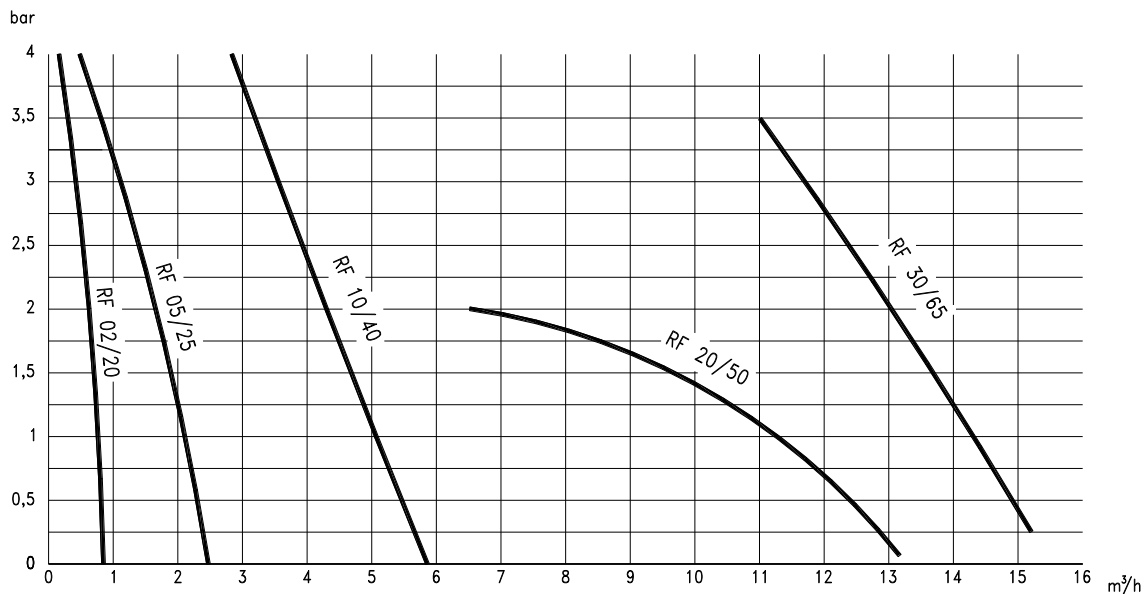

1450 r.p.m.

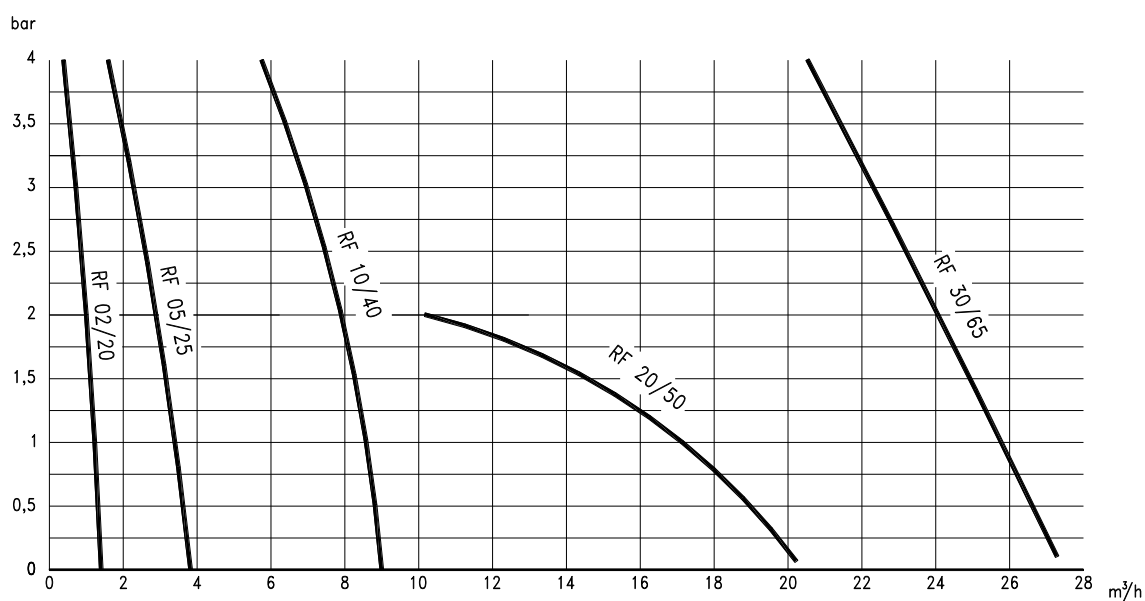

The range of application for each type of pump is limited. The pump was selected for a given set of pumping conditions when the order was placed. INOXPA shall not be liable for any damage resulting from the incompleteness of the information provided by the purchaser (nature of the fluid, RPM, etc.).

4. Installation

4.1. RECEPTION OF THE PUMP



INOXPA cannot be held responsible for the damage sustained by the equipment during transport or unpacking. Please visually check that the packaging is not damaged.

The pump package includes the following documents:

- Dispatch sheets.
 - Instruction and Service Manual of the pump.
 - Instruction and Service Manual of the motor (*)
- (*) when the pump is supplied with an motor by INOXPA.

Unpack the pump and check the following:

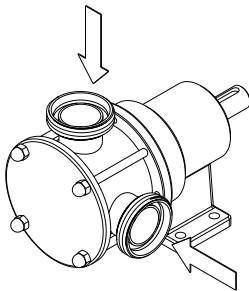

- The suction and discharge connections of the pump, removing any rest of packaging materials.
- The pump and the motor are not damaged.
- If the equipment is not in good condition and/or any part is missing, the carrier should report accordingly as soon as possible.

4.1.1. Identification of the pump

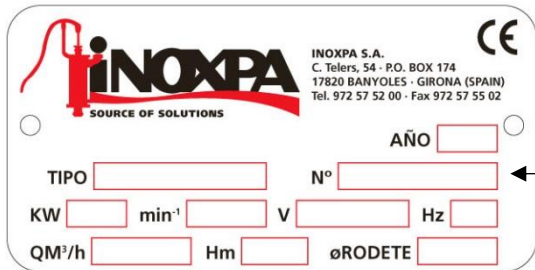

INOXPA S.A.
C. Teleris, 54 - P.O. BOX 174
17820 BANYOLES - GIRONA (SPAIN)
Tel. 972 57 52 00 - Fax 972 57 55 02

CE

TIPO AÑO

Nº ← Serial number

KW min⁻¹ V Hz

QM³/h Hm øRODETE

Pump plate

4.2. HANDLING AND STORAGE



RF pumps are often too heavy to be handled and stored manually.

Lift the pump as shown below:

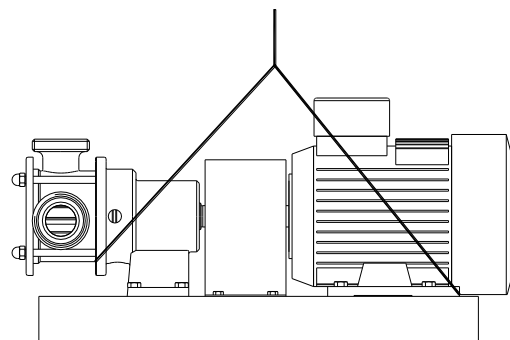
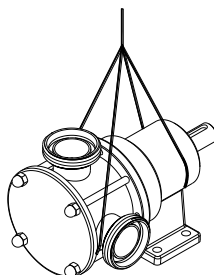
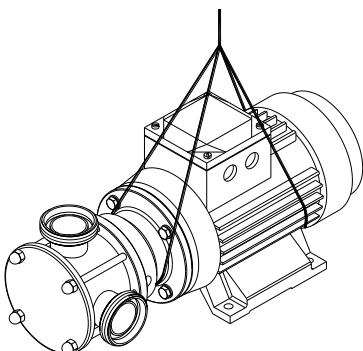

4.3. LOCATION

Place the pump as close as possible to the suction tank, and if possible below the fluid level.

Place the pump so as to allow around it space enough to access the pump and the motor. (See Chapter 8 *Technical Specifications* for dimensions and weight).

Mount the pump on a flat, level surface.

The foundation must be rigid, horizontal, level and vibration-proof.



Install the pump so as to allow proper ventilation.

If the pump is installed outdoors, it should be covered by a roof. Its location should allow easy access for inspection or maintenance operations.

4.4. PIPES

- As general rule, fit the suction and discharge pipes in straight sections, with the least possible number of bends and accessories in order to reduce as much as possible any loss of load caused by friction.
- Ensure that the nozzles of the pump are properly aligned to the pipe and their diameter is similar to that of the pump connections.
- Place the pump as close as possible to the suction tank, if possible below the fluid level, or even below the tank, so that the manometric head of the static suction is highest.
- Place pipe supports as close as possible to the suction and discharge nozzles of the pump.

4.4.1. Cut-off valves

The pump can be isolated for maintenance purposes. To such end, cut-off valves must be fitted to the suction and discharge nozzles of the pump.

These valves must ALWAYS be open during operation of the pump.

4.5. ELECTRIC WIRING



The connection of the electrical motors must be performed by a qualified operative. Take all necessary precautions to prevent the failure of connections and cables.



The electrical equipment, the terminals and the components of the control systems may still bear electrical current when powered off. Contact with them may be dangerous for operators or cause irreversible damage to equipment.

Before handling the pump, make sure that the switchboard is not powered on.

- Connect the motor following the manufacturer's instructions.
- Check the direction of rotation.

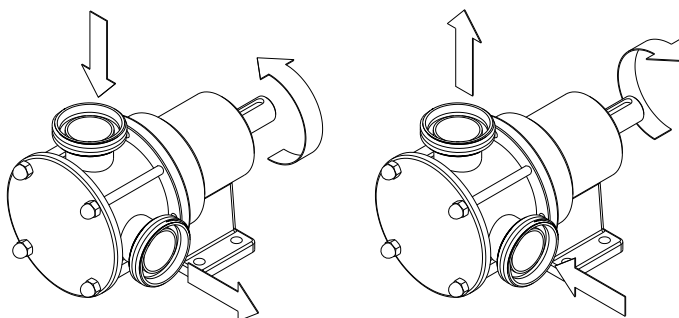

Start the pump motor briefly. Ensure the pumping direction is the right one. If the pump operates in the wrong direction it may cause severe damage.



ALWAYS check the direction of rotation of motor with fluid inside de pump.

For models with a seal chamber, ALWAYS ensure that the chamber is full of fluid before checking the direction of rotation.

5. Start-up



Before starting the pump, carefully read the instructions given in Chapter 4. *Installation*.

5.1. START-UP



Read Chapter 8 *Technical Specification* carefully. INOXPA cannot be held responsible for the improper use of the equipment.



NEVER touch the pump or the pipes when hot fluid is being pumped.

5.1.1. Checks before starting up the pump

- Fully open the cut-off valves on the suction and discharge pipes.
- If the fluid does not flow into the pump, fill the pump with fluid.



The pump must **NEVER** rotate without fluid inside it.

- Check that the direction of rotation of motor is the right one.

5.1.2. Checks when starting up the pump

- Check whether the pump makes strange sounds.
- Check whether the absolute inlet pressure is enough to avoid cavitation in the pump. See the curve to determine the minimum pressure required above steam pressure (NPSHr).
- Control discharge pressure.
- Check that there are no leaks through the sealed areas.



A cut-off valve on the suction pipe must no be used to regulate flow. Cut-off valves must be fully open during operation.



Control motor consumption to avoid power overload.

Reduce flow and motor power consumption by reducing motor speed.

In order to prevent to work over the desing pressure, avoiding damaging the pump and having fast wear of the rotor, a **flow by-pass** is needed.

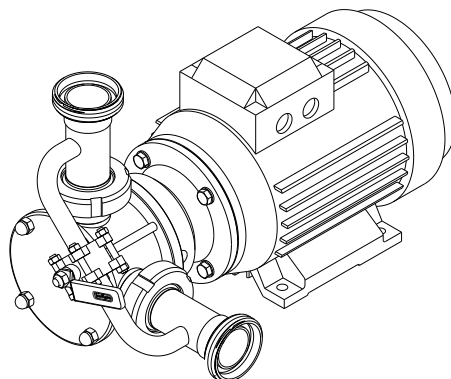

6. Operating problems

The following table provides solutions to problems that might arise during the operation of the pump. The pump is assumed to have been properly installed and be suitable for the relevant application. Please contact INOXPA if technical assistance is required.

Operating problems	Probable causes
Motor overload	8, 12, 13, 19, 20, 21, 22, 23.
The pump does not provide enough flow or pressure	1, 2, 4, 5, 7, 8, 9, 16, 18.
No pressure on the discharge side	2, 3, 6, 17, 18, 24.
Uneven discharge flow / pressure	1, 2, 4, 5, 6, 8, 24.
Noise and vibration	2, 4, 5, 6, 7, 8, 9, 12, 13, 14, 19, 20, 21, 22, 23.
The pump gets clogged	8, 9, 12, 13, 14, 19, 20, 21, 22, 23.
Overheated pump	8, 9, 12, 13, 14, 19, 20, 21, 22, 23.
Excessive wear	4, 5, 9, 13, 14, 19, 23, 24.
The mechanical seal leaks	10, 11, 15.

Probable causes	Solutions
1 Wrong direction of rotation	Reverse the direction of rotation
2 NPSH is not high enough	Increase the available NPSH: - Place the suction tank higher - Place the pump lower - Reduce steam pressure - Increase the diameter of the suction pipe - Shorten and simplify the suction pipe
3 Pump not drained	Drain or fill
4 Cavitation	Increase suction pressure (see also 2)
5 Air is suctioned by the pump.	Check the suction pipe and all its connections
6 Clogged suction pipe	Check the suction pipe and all its filters, if any
7 Discharge pressure too high	If necessary, reduce load losses, e.g. by increasing the diameter of the pipe, or including a by-pass.
8 Fluid viscosity too high	Reduce the viscosity, e.g. by heating the fluid
9 Fluid temperature too high	Reduce the temperature by cooling the fluid
10 Mechanical seal damaged or worn out	Replace the seal
11 O-rings unsuitable for the fluid	Fit suitable O-rings. Consult the manufacturer.
12 Excessive impeller expansion	- Reduce temperature - Change the impeller
13 Stressed pipes	Connect the pipes to the pump so as to avoid stress
14 Foreign matter in the fluid	Fit a filter to the suction pipe
15 The mechanical seal tension is too low	Adjust according the instructions of this Manual
16 Pump speed too low	Increase speed
17 The cut-off valve on the suction side is closed	Check and open
18 Pump too small	Choose a larger pump size
19 Bearings are worn out	Replace bearings; review the pump
20 Low lubricating oil level	Refill with lubricating oil
21 Unsuitable lubricating oil	Use suitable lubricating oil
22 Misaligned coupling	Align the coupling properly
23 Pump and/or motor not attached to the baseplate.	Attach the pump and/or motor and check whether the pipes are connected without stress and align the coupling
24 Impeller is worn out or has operated in vacuum	Replace the impeller



If the problem persists, use of the pump must cease immediately. Contact the pump's manufacturers or their representative.

7. Maintenance

7.1. GENERAL

Like any other machine, this pump requires maintenance. The instructions included in this manual cover the identification and replacement of spare parts. These instructions are intended for the maintenance personnel and those responsible for the supply of spare parts.



Please carefully read Chapter 8 *Technical Specification*.

All replaced materials must be disposed of /recycled in accordance to the applicable local regulations.



ALWAYS disconnect the pump from the power before performing the maintenance.

7.1.1. Check the mechanical seal

Regularly check that there are no leaks in the shaft area. If there are leaks through the mechanical seal, replace it following the instructions given under the *Disassembly and Assembly* section.

7.2. STORAGE

The pump must be completely emptied of fluid before storage. If possible, avoid exposing the components of the pump to excessively humid environments.



Flexible impellers must be stored in a dry place protected from direct sunlight.

Remove the impeller when the pump will not be used for a long time.

7.3. CLEANING



The use of aggressive cleaning products, such as caustic soda and nitric acid, can cause skin burns.

Use rubber gloves during cleaning procedures.



Always use protective goggles.

7.3.1. Automatic CIP (cleaning-in-place)

If the pump is installed in a system with a CIP process, it is not necessary to disassemble the pump.

If the automatic cleaning process is not provided, proceed to disassemble the pump as indicated in the *Disassembly and Assembly* section.

Cleaning solutions for CIP processes

Use only clear water (without chlorides) for mixing with the cleaning agents:

a) Alkaline solution: 1% in weight of caustic soda (NaOH) at 70°C (150°F)

1 Kg NaOH + 100 l. water = cleaning solution

or

2.2 l. NaOH at 33% + 100 l. water = cleaning solution

b) Acid solution: 0.5% in weight of nitric acid (HNO₃) at 70°C (150°F)

0.7 liters HNO₃ at 53% + 100 l. water = cleaning solution



Control the concentration of the cleaning solutions to avoid deterioration of the pump seals.

To remove the remaining cleaning products, ALWAYS perform a final rinse with clean water on completion of the cleaning process.

7.3.2. Automatic SIP (sterilization-in-place)

The process of sterilization with steam is applied to all the equipment including the pump.



Do NOT start the equipment during the process of sterilization with steam. The parts/materials suffer no damage if the indications specified in this manual are observed.

No cold liquid can enter the equipment till the temperature of the equipment is lower than 60°C (140°F).

A flow by-pass is recommended to be used in order to assure the flow of sterile product after the pump.

Maximum conditions during the SIP process with steam or overheated water

a)	Max. temperature:	140°C / 284°F
b)	Max. time:	30 min
c)	Cooling:	Sterile air or inert gas
d)	Materials:	EPDM / PTFE (recommended) FPM / NBR (not recommended)

7.4. DISASSEMBLY / ASSEMBLY OF THE PUMP

7.4.1. Pump casing, impeller and mechanical seal

← Disassembly

Loosen the blind nuts (45) and detach the pump cover (03). Then, pull out the casing (01) together with the impeller (02). Remove the stationary part of the mechanical seal (08), the O-ring (80) and the tie bars (29) from the casing. Finally, remove the rotary part of the seal (08) and the splash ring (82) from the shaft.

⇒ Assembly

Slide the splash ring (82) over the shaft (05), but do not push it to the end. Slide the rotary part of the seal (05/05A) to the stop. Insert the impeller (02) and the stationary part of the seal (08) into the casing (01). Gently fit all the assembly into the lantern (04), or the ball bearing (06) for the bareshaft pump. Place the O-ring (80) on the casing (01) and fasten the tie bars (29). Mount the cover (03) and fasten it all with the blind nuts (45).

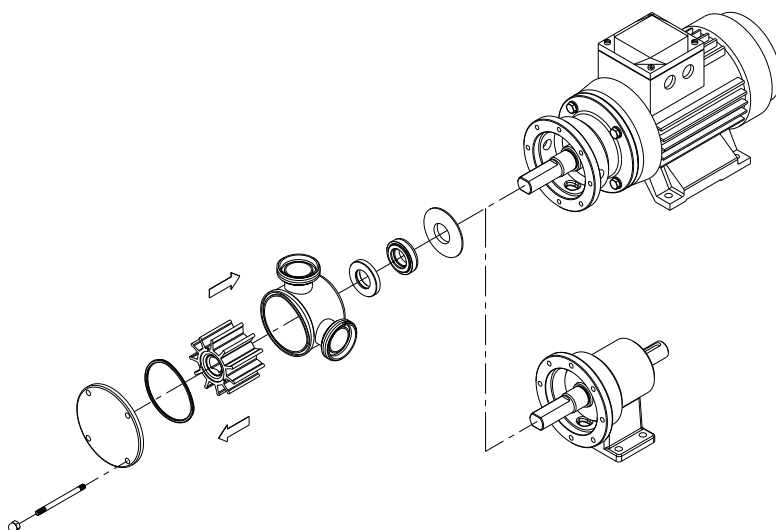

CAUTION! When mounting the new seal, plunge the parts and seals in soapy water to facilitate sliding of both the stationary and the rotary parts.

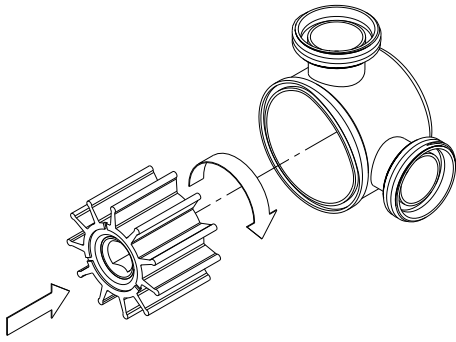

Before the impeller (02) is mounted, it should be lubricated with grease. For food-processing applications, use health-safe grease.
Insert the impeller (01) into the casing (01) and rotate it in the direction of rotation.

7.4.2. Change of drive (monoblock pump)

Disassembly

Loosen and remove the hexagonal screws (52) and the washers (53). Remove the lantern (04) from the motor (93). Remove the pin (56) that makes the motor shaft and the pump shaft rotate in conjunction. Finally, remove the shaft (05B).

Assembly

Drill a hole in the drive shaft according to the dimension shown in the figure below. Mount the pump shaft (05B) to the motor shaft. Insert the pin (56) through the shaft. Mount the lantern (04) to the motor flange (93) and fasten it with the hexagonal screws (52) and the washers (53).

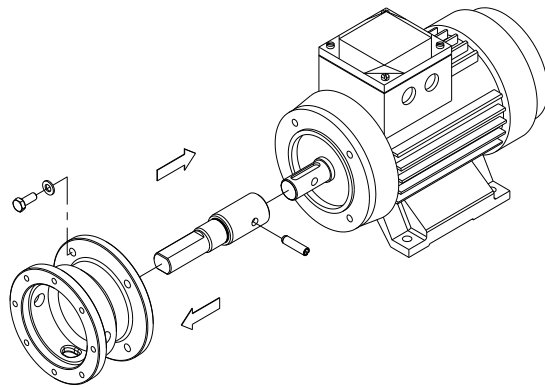

Motor size	A	∅
T.80	20	6
T.90	25	8
T.100	30	8

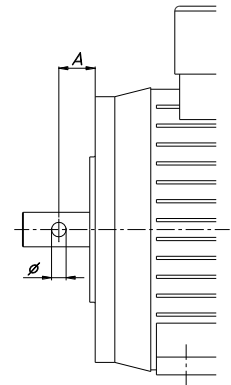

7.4.3. Change of bearings (bareshaft pump)

Disassembly

Remove the bearings support (06), the seal (88) and the elastic ring (66). Pull out the assembly formed by the shaft (05), bearings (70), elastic ring (66A) and stop ring (31). Remove the elastic ring (66A) and the ring (31). Finally, remove the bearings (70A) and the spacer bushing (17).

Assembly

Mount the bearings (70A) and the spacer bushing (17) to the shaft (05). Place the stop ring (31) and attach it using the elastic ring (66A). Mount the assembly to the bearings support (06) and attach it using the elastic ring (66).

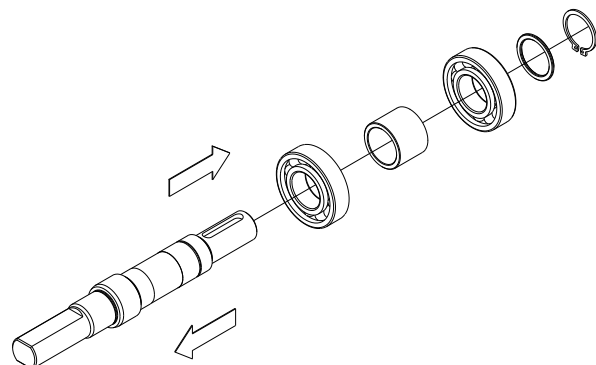
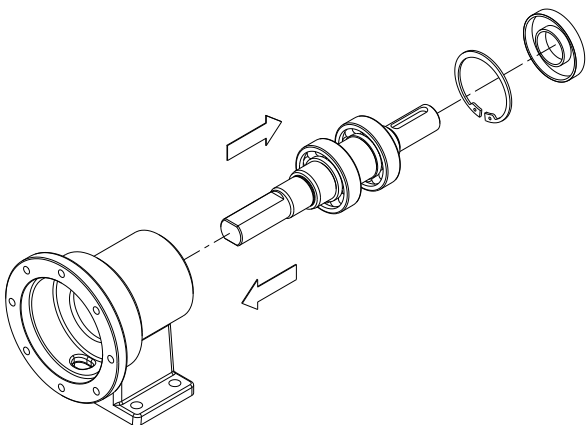

7.4.4. Disassembly of the flushing seal

← **Disassembly**

First disassemble the pump casing and the impeller as in 7.4.1. Gently remove the flushing cover (10), which will now be placed on the lantern (04), or the ball bearing (06) for the bareshaft pump. Finally, remove the stainless steel spring seal (88B) and the (80A) from the lantern.

⇒ **Assembly**

Mount the seal (88B) and the O-ring (80) to the flushing cover (10), and taking care not to damage the seal (88B), mount the assembly to the lantern (04), or the ball bearing (06) for the bareshaft pump.

7.4.5. Disassembly of the double seal cover

← **Disassembly**

First disassemble the pump casing and the impeller as in 7.4.1. The double seal cover (09) will now be placed on the body (01). Loosen the Allen screws (51) and detach the double seal cover (09). Remove the two stainless steel spring seals (08B), the spacer bushing (17B) and the O-ring (80B) from the double seal cover.

⇒ **Assembly**

Mount the seals (08B) separated by the bushing (17) to the double seal cover (09A), and place also the O-ring (80B) into its housing. Fit the assembly into the casing (01) and fasten with the Allen screws (51). Finally, mount the assembly to the lantern (04) or the support (06), taking care not to damage the seals (08B).

8. Technical specifications

8.1. TECHNICAL SPECIFICATIONS

Maximum flow (1450 rpm)	30 m ³ /h
Maximum differential pressure	Table attached
Maximum suction pressure	4 bar (58 PSI)
Maximum operating pressure	8 bar (116 PSI)
Operating temperature	+3 °C to +80°C / 37 °F to 176 °F
Sound level	60-80 dB(A)
Suction / discharge connections	DIN 11851 (standard)

Pump type	Starting torque (Nm)	Reverse torque (Nm)	Maximum differential pressure (bar)	
			Monoblock	Bareshaft
RF-02/20	4,7	7,1	3	4
RF-05/25	7,3	13,4	2,5	4
RF-10/40	15,1	31,6	2,5	4
RF-20/50	24,4	51,6	2	2
RF-30/65	64,3	110,5	----	4

If the pump is operated beyond the limit values indicated, shaft might be damaged or broken and impeller can be quickly damaged.

ATTENTION! The use of a frequency drive can cause a decrease of the motor starting torque.



Use special protection when the noise level in the operation area exceeds 85 dB(A).

Materials

Impeller	Neoprene
Parts in contact with pumped material	AISI 316L
Other parts in stainless steel	AISI 304
Gaskets in contact with pumped material	NBR (standard)
Other materials for optional gaskets	Check with the supplier
Surface finishing	Standard polishing

Mechanical seal

Type of seal	Single outside seal
Stationary parts material	Ceramic
Rotary parts material	Graphite
Seals material	NBR

Cooled mechanical seal

Maximum pressure	0.5 bar (7 PSI)
Consumption	2.5-5 l/min

8.2. WEIGHTS

Pump type	Bareshaft		Monoblock	
	Weight [Kg]	Weight [lbs]	Weight [Kg]	Weight [lbs]
RF-02/20	4.5	10	14	31
RF-05/25	5	11	15	33
RF-10/40	9	20	25	55
RF-20/50	17	37	37	82
RF-30/65	21	46		

8.3. BEARINGS MAINTENANCE

The bareshaft pump RF bearings are permanently greased bearings, so no lubrication maintenance is required. Under normal working duties, they must be changed after 15.000 working hours.

Regarding motor bearings shall be carried out in accordance with the manufacturer's instructions.

8.4. RF PUMP DIMENSIONS (MONOBLOCK)

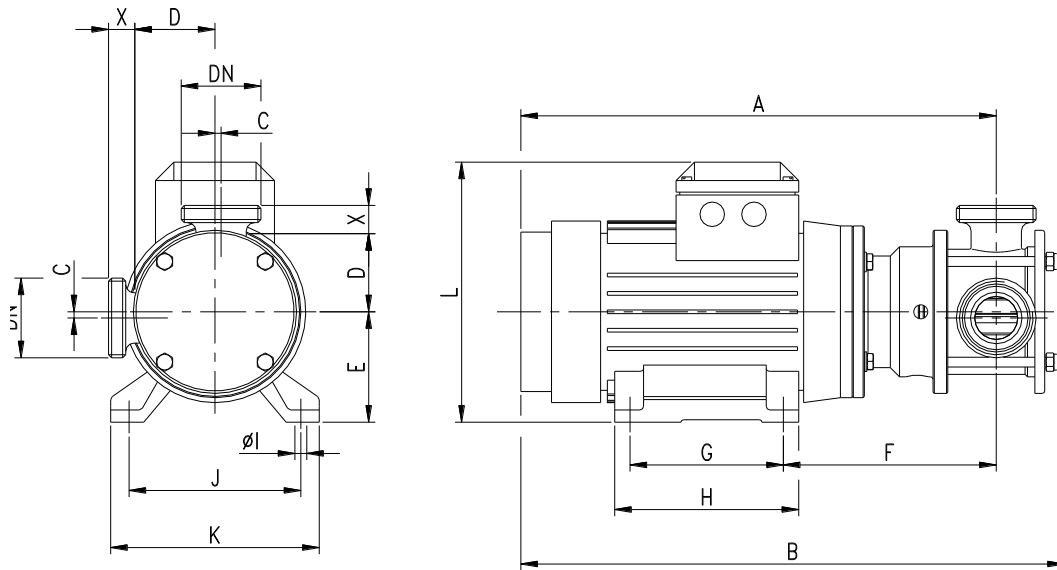

Pump type	Motor	DN	A	B	C	D	E	F	G	H	φI	J	K	L	X		
															DIN	SMS	CLAMP
RF-02/20	80	25	330	350	2	51,5	80	139	100	125	9	125	155	220	22	19	12,5
RF-05/25		25	340	370		55,5		148									
RF-10/40	90	40	410	445	5	66	90	174	125	155	10	140	180	240			
RF-20/50	100	50	460	510	6,5	80	100	205	140	180	12	160	200	265			

8.5. RF PUMP DIMENSIONS (BARESHAFT)

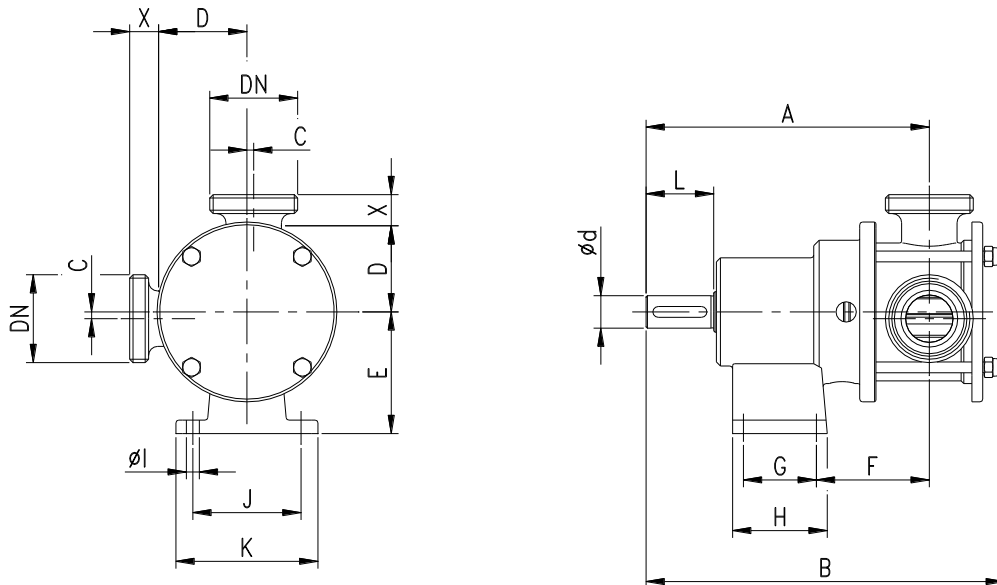

Pump type	DN	φd	A	B	C	D	E	F	G	H	φI	J	K	L	X		
															DIN	SMS	CLAMP
RF-02/20	25	19	172	206	2	51,5	80	74	30	60	9	70	90	40	22	19	12,5
RF-05/25	25		181	225		55,5		83									
RF-10/40	40	24	210	265	5	66	90	88	45	70	10	80	105	50			
RF-20/50	50	28	272	335	6,5	80	100	109	75	105	11	90	120	60	23	27	
RF-30/65	65		280	350	10	85		117							25		

8.6. RF PUMP DIMENSIONS (BARESHAFT WITH BASE PLATE)

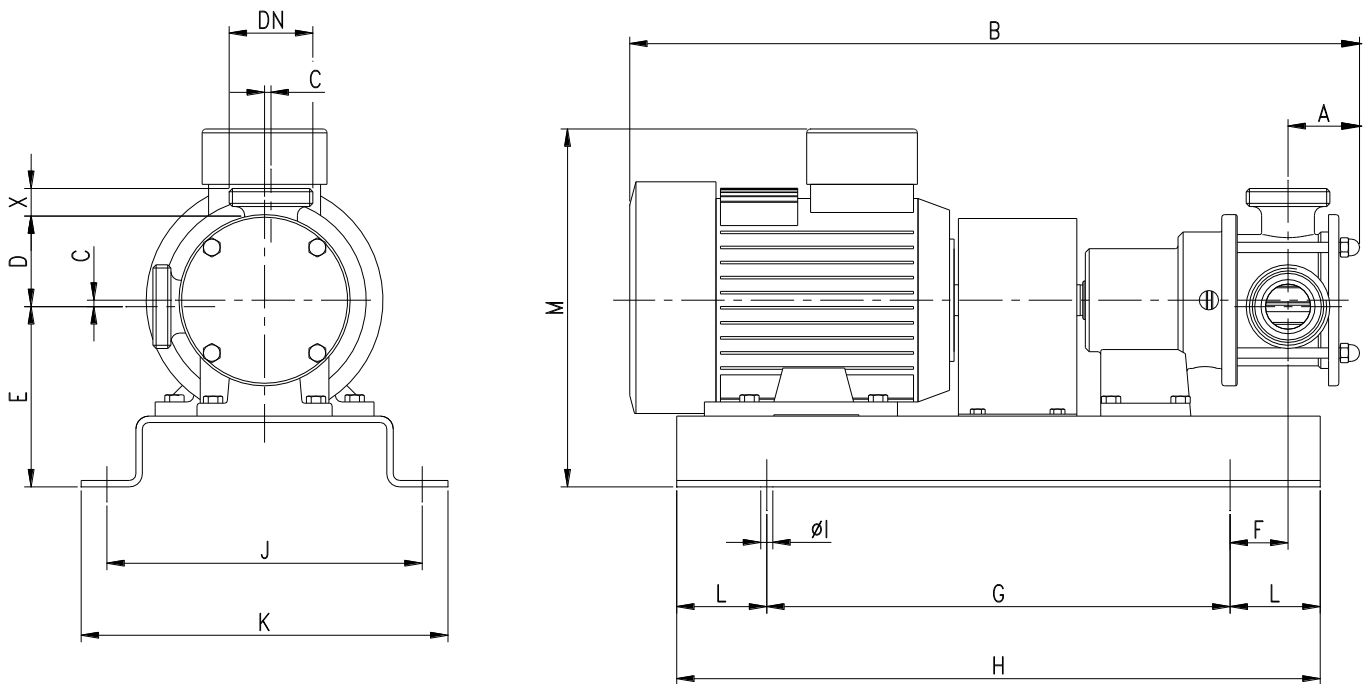

Pump type	Motor	DN	A	B	C	D	E	F	G	H	øI	J	K	L	M	X		
																DIN	SMS	CLAMP
RF-02/20	80	25	34	474	2	70	135	25	360	500	15	245	285	70	260	22	19	12,5
RF-05/25	80	25	44	493														
RF-10/40	90	40	55	588	5	87	145	45	470	650	295	335	90	300	23	23		
RF-20/50	100	50	63	696	6,5	103	155	50										
RF-30/65	100	65	70	711	10	112	155	65	550	750	19	355	410	100	366	25	27	
	112			741			167											
	132			800			202											55

8.7. RF PUMP

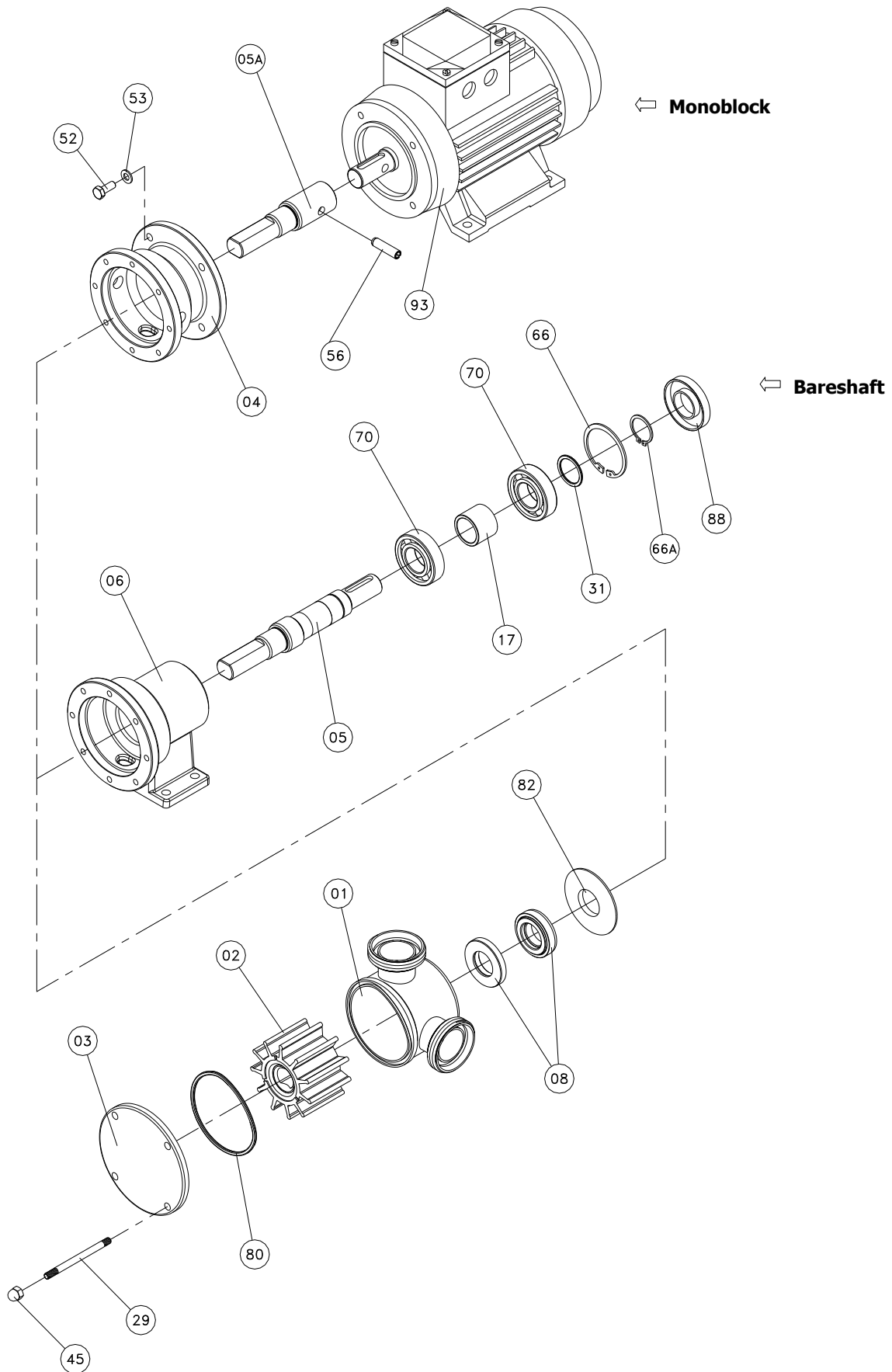

8.8. RF PUMP (MONOBLOCK)

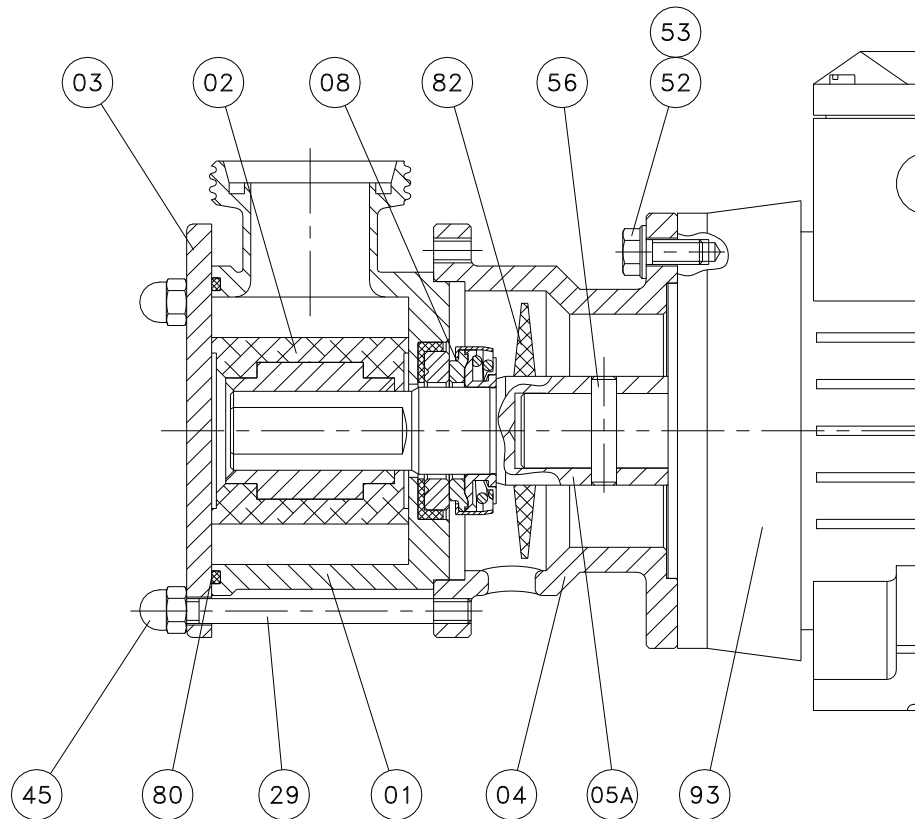

8.9. PARTS LIST RF

Position	Description	Quantity	Material
01	Pump casing	1	AISI 316L
02	Impeller *	1	NEOPRENE
03	Pump cover	1	AISI 316L
04	Lantern	1	GG 15
05A	Shaft	1	AISI 316L
08	Mechanical seal *	1	Cer/C/NBR
29	Tie bar	4	AISI 304
45	Blind nut	4	A2
56	Elastic pin	1	A2
52	Hexagonal screw	4	8.8
53	Flat washer	4	steel
80	O-ring *	1	NBR
82	Splash ring	1	EPDM
93	Motor	1	-

(*) Recommended spare parts

8.10. RF PUMP (BARESHAFT)

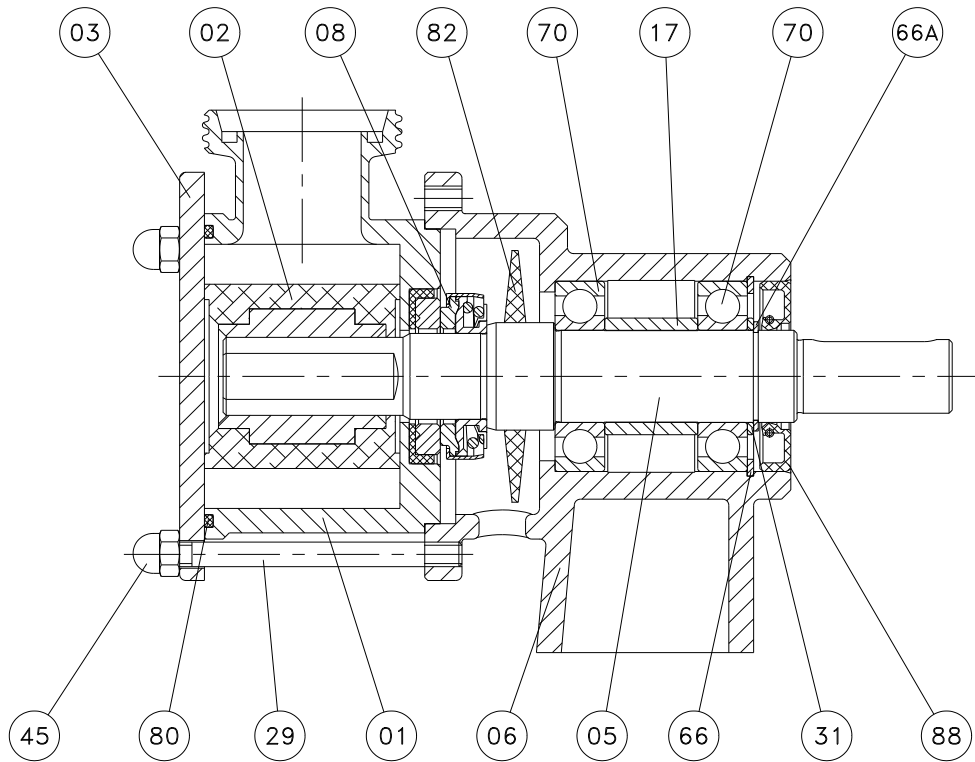

8.11. PARTS LIST RF (BARESHAFT)

Position	Description	Quantity	Material
01	Pump casing	1	AISI 316L
02	Impeller *	1	NEOPRENE
03	Pump cover	1	AISI 316L
05	Shaft	1	AISI 316L
06	Bearings support	1	GG15
08	Mechanical seal *	1	Cer/C/NBR
17	Spacer bushing	1	F-114
29	Tie bar	4	AISI 304
31	Stop ring	1	F-114
45	Blind nut	4	A2
66	Elastic ring	1	Steel
66A	Elastic ring	1	Steel
70	Bearing *	2	Steel
80	O-ring *	1	NBR
82	Splash ring	1	EPDM
88	Seal *	1	NBR

(*) Recommended spare parts

8.12. SEALING OPTIONS

8.12.1. Flushing seal

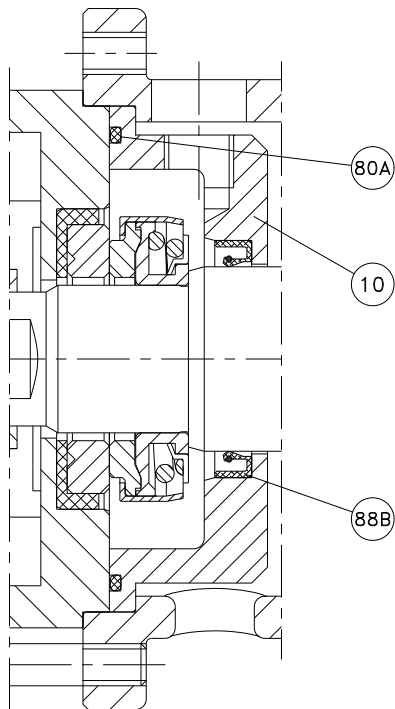

Position	Description	Quantity	Material
10	Flushing cover	1	AISI 316L
80A	O-ring *	1	NBR
88B	Stainless steel spring seal *	1	NBR

8.12.2. Double seal

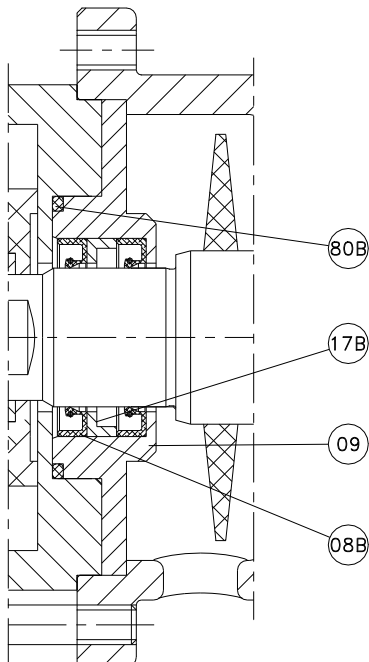

Position	Description	Quantity	Material
09	Double seal cover	1	AISI 316L
17B	Spacer bushing	1	AISI 316L
80B	O-ring *	1	NBR
08B	Stainless steel seal *	2	NBR

(*) Recommended spare parts

**INOXPA, S.A.**

c/ Telers, 54 – PO Box 174
17820 BANYOLES (GIRONA)
Tel: 34 972575200
Fax: 34 972575502
e-mail: inoxpa@inoxpa.com
www.inoxpa.com

DELEGACIÓN LEVANTE

PATERNA (VALENCIA)
Tel: 963 170 101
Fax: 963 777 539
e-mail: inoxpa.levante@inoxpa.com

LA CISTÉRNIGA (VALLADOLID)

Tel: 983 403 197
Fax: 983 402 640
e-mail: sta.valladolid@inoxpa.com

INOXPA SOLUTIONS LEVANTE

PATERNA (VALENCIA)
Tel: 963 170 101
Fax: 963 777 539
e-mail: isf@inoxpa.com

ST. SEBASTIEN sur LOIRE

Tel/Fax: 33 130289100
e-mail: inoxpa.fr@inoxpa.com

INOXPA ALGERIE

ROUIBA
Tel: 213 21856363 / 21851780
Fax: 213 21854431
e-mail: inoxpalgerie@inoxpa.com

INOXPA UK LTD

SURREY
Tel: 44 1737 378 060 / 079
Fax: 44 1737 766 539
e-mail: inoxpa-uk@inoxpa.com

INOXPA SKANDINAVIEN A/S

HORSENS (DENMARK)
Tel: 45 76 286 900
Fax: 45 76 286 909
e-mail: inoxpa.dk@inoxpa.com

**INOXPA SPECIAL PROCESSING
EQUIPMENT, CO., LTD.**

JIAXING (China)
Tel.: 86 573 83 570 035 / 036
Fax: 86 573 83 570 038

INOXPA WINE SOLUTIONS

VENDARGUES (FRANCE)
Tel: 33 971 515 447
Fax: 33 467 568 745
e-mail: frigail.fr@inoxpa.com /
npourtaud.fr@inoxpa.com

DELEGACIÓN NORD-ESTE /

BARBERÀ DEL VALLÈS (BCN)
Tel: 937 297 280
Fax: 937 296 220
e-mail: inoxpa.nordeste@inoxpa.com

DELEGACIÓN CENTRO

ARGANDA DEL REY (MADRID)
Tel: 918 716 084
Fax: 918 703 641
e-mail: inoxpa.centro@inoxpa.com

LOGROÑO

Tel: 941 228 622
Fax: 941 204 290
e-mail: sta.rioja@inoxpa.com

INOXPA SOLUTIONS FRANCE

GLEIZE
Tel: 33 474627100
Fax: 33 474627101
e-mail: inoxpa.fr@inoxpa.com

WAMBRECHIES

Tel: 33 320631000
Fax: 33 320631001
e-mail: inoxpa.nord.fr@inoxpa.com

INOXPA SOUTH AFRICA (PTY) LTD

JOHANNESBURG
Tel: 27 117 945 223
Fax: 27 866 807 756
e-mail: sales@inoxpa.com

S.T.A. PORTUGUESA LDA

VALE DE CAMBRA
Tel: 351 256 472 722
Fax: 351 256 425 697
e-mail: comercial.pt@inoxpa.com

IMPROVED SOLUTIONS

VALE DE CAMBRA
Tel: 351 256 472 140 / 138
Fax: 351 256 472 130
e-mail: isp.pt@inoxpa.com

INOXRUS

MOSCOW (RUSIA)
Tel / Fax: 74 956 606 020
e-mail: moscow@inoxpa.com

INOXPA UCRANIA

KIEV
Tel: 38 050 720 8692
e-mail: kiev@inoxpa.com

ZARAGOZA

Tel: 976 591 942
Fax: 976 591 473
e-mail: inoxpa.aragon@inoxpa.com

DELEGACIÓN STA

GALDACANO (BILBAO)
Tel: 944 572 058
Fax: 944 571 806
e-mail: sta@inoxpa.com

DELEGACIÓN SUR

JEREZ DE LA FRONTERA (CÁDIZ)
Tel / Fax: 956 140 193
e-mail: inoxpa.sur@inoxpa.com

CHAMBLY (PARIS)

Tel: 33 130289100
Fax: 33 130289101
e-mail: isf@inoxpa.com

INOXPA AUSTRALIA PTY (LTD)

MORNINGTON (VICTORIA)
Tel: 61 3 5976 8881
Fax: 61 3 5976 8882
e-mail: inoxpa.au@inoxpa.com

INOXPA USA, Inc

SANTA ROSA
Tel: 1 7075 853 900
Fax: 1 7075 853 908
e-mail: inoxpa.us@inoxpa.com

INOXPA ITALIA, S.R.L.

BALLO DI MIRANO – VENEZIA
Tel: 39 041 411 236
Fax: 39 041 5128 414
e-mail: inoxpa.it@inoxpa.com

INOXPA INDIA PVT. LTD.

Maharashtra, INDIA.
Tel: 91 2065 008 458
inoxpa.in@inoxpa.com

SAINT PETERSBURG (RUSIA)

Tel: 78 126 221 626 / 927
Fax: 78 126 221 926
e-mail: spb@inoxpa.com

INOXPA products are available from our branch offices and through a network of independent distributors covering more than 50 countries around the World. For more information, visit our Web site: www.inoxpa.com

This information is given for guidance only. We reserve the right to change any materials or characteristics without prior notice.