



INSTALLATION, SERVICE AND MAINTENANCE INSTRUCTIONS

VEEVALV '09



INOXPA, S.A.

c/Telers, 54 Apto. 174

E-17820 Banyoles

Girona (Spain)

Tel. : (34) 972 - 57 52 00

Fax. : (34) 972 - 57 55 02

Email: inoxpa@inoxpa.com

www.inoxpa.com



Original Manual

10.300.30.02EN
(B) 2017/06



EC Declaration of Conformity

The designated Company

INOXPA, S.A.

c/ Telers, 54

17820 Banyoles (Girona), Spain

herewith declares under our sole responsibility that the machine

Valve

Model

Diaphragm

Types

VEEVALV

from serial number I250000 to I400000 ⁽¹⁾

⁽¹⁾ the serial number can be preceded by a slash and by one or two alphanumeric characters

is in conformity to the all relevant provisions of the following directives:

Machinery Directive 2006/42/EC

Pressure equipment Directive 2014/68/EU

The Technical Construction file is maintained and compiled by DAVID REYERO, c/ Telers nº 54, 17820 Banyoles.

Signed for and on behalf of:

INOXPA, S.A.

Place and date issue

Banyoles, March 30, 2017

Name, function

David Reyero Brunet, Technical Office Manager

Signature or equivalent authorized by the issuer

1. Safety

1.1. INSTRUCTION MANUAL.

This instruction manual contains basic operations which should be fulfilled during the installation, starting and maintenance.

The information published in the instruction manual is based on updated information. INOXPA reserves the right to modify this instruction manual without prior notice.

1.2. START-UP INSTRUCTIONS.

This instruction manual contains vital and useful information to correctly install and maintain your valve.

Not only should the safety instructions indicated in this chapter be observed and fulfilled, but so should the special measures and recommendations included in the other chapters of this manual. These instructions should be kept in a safe location near the installation.

1.3. SAFETY.

1.3.1. Warning symbols.



Danger for persons in general



Danger of injury caused by rotating equipment parts.



Electrical danger



Danger! Caustic or corrosive agents.



Danger! Suspended loads



Danger to the correct operation of the equipment.



Commitment to safety at the workplace.



Protective goggles requirement.

1.4. GENERAL SAFETY INSTRUCTIONS



Read the instruction manual carefully before installing and starting up the valve. Contact INOXPA in case of doubt.

1.4.1. During the installation.



The *Technical Specifications* of Chapter 8 should always be observed.

The installation and use of the valve should always be carried out in accordance with applicable regulations regarding health and safety.

Before starting up the valve, verify that the assembly is correct and that the shaft is aligned. An incorrect alignment and/or excessive force in securing the valve may cause serious mechanical problems in the valve. Check that the diaphragm has been assembled correctly. If it has been located incorrectly this may seriously damage the valve.

1.4.2. During operation.



The *Technical Specifications* of Chapter 8 should always be observed. The specified maximum parameters must NEVER be exceeded.



NEVER touch the valve and/or pipes that are in contact with the liquid during operation. If working with hot fluids there is a risk of burns.



The valve contains components which have linear movement. Do not place hands or fingers in the valve closure area as this may cause serious injury.

1.4.3. During maintenance



The *Technical Specifications* of Chapter 8 should always be observed.

NEVER disassemble the valve until the pipes have been emptied. Bear in mind that the liquid in the pipe may be dangerous or extremely hot. Consult the regulations in effect in each country for these cases.

Do not leave parts loose on the floor.



All electrical work should be carried out by authorized personnel.

1.4.4. Compliance with the instructions.

Any non-compliance with the instructions may result in a risk for the operators, the environment and the machine, and may lead to a loss of your right to claim damages.

This non-compliance may result in the following risks:

- Failure of important functions of the machine/plant.
- Failure of specific maintenance and repair procedures.
- Possibility of electric, mechanical and chemical risks.
- Will place the environment in danger due to the release of substances.

1.5. GUARANTEE.

Any guarantee will be cancelled immediately and as a matter of law and, in addition, we will require compensation for any claims of civil liability presented by third parties, in case:

- The installation and maintenance work has not been carried out according to the instructions of this manual.
- The repairs are not carried out by our personnel or have been carried out without our written authorization.
- The parts used are not INOXPA genuine parts.
- Modifications have been carried out on our materials without written authorization.
- The material has been badly used, incorrectly used, or used with negligence or has not been used according to the indications and intended use specified in this manual.

The general conditions of delivery already in your possession are also applicable.



No change can be made to the equipment without prior discussion with the manufacturer. For your safety, please use original spare parts and accessories. The use of other parts will exempt the manufacturer from any liability.

The service terms can only be changed with prior written authorization from INOXPA.

Please do not hesitate to contact us in case of doubts or more complete explanations are required on specific data (adjustments, assembly, disassembly, etc.).

2. Table of Contents

1. Safety	
1.1. Instruction manual.....	3
1.2. Start-up instructions.....	3
1.3. Safety.....	3
1.4. General safety instructions.....	3
1.5. Guarantee.....	4
2. Table of Contents	
3. Receipt and Installation	
3.1. Checking the shipment.....	6
3.2. Delivery and unpacking.....	6
3.3. Storage.....	6
3.4. Identification.....	7
3.5. Location.....	7
3.6. Assembly.....	8
3.7. Inspecting and checking.....	8
3.8. Welding.....	9
3.9. Air connection to actuator.....	9
4. Start-up	
4.1. Start-up.....	10
4.2. Operation.....	10
5. Operating Problems: Causes and Solutions	
6. Maintenance	
6.1. general.....	12
6.2. Maintenance.....	12
6.3. Cleaning.....	13
7. Assembly and Disassembly	
7.1. Disassembly / Assembly of the manually actuated valve.....	14
7.2. Procedure for adjusting to closure of the manual valve.....	15
7.3. Disassembly / Assembly of the pneumatically actuated valve.....	16
8. Technical Specifications	
8.1. Manually actuated valve dimensions.....	19
8.2. Stainless-steel pneumatically actuated valve dimensions.....	20
8.3. Section and parts list.....	21

3. Receipt and Installation

3.1. CHECKING THE SHIPMENT

The first thing to do on receiving the valve is to verify that it is as specified on the delivery note. The valve and any other components should be checked and if found to be damaged and/or not complete the carrier should be informed and a report submitted as soon as possible. Each valve is identified with an engraved manufacturing/serial number and this must be included in all documents and correspondence.

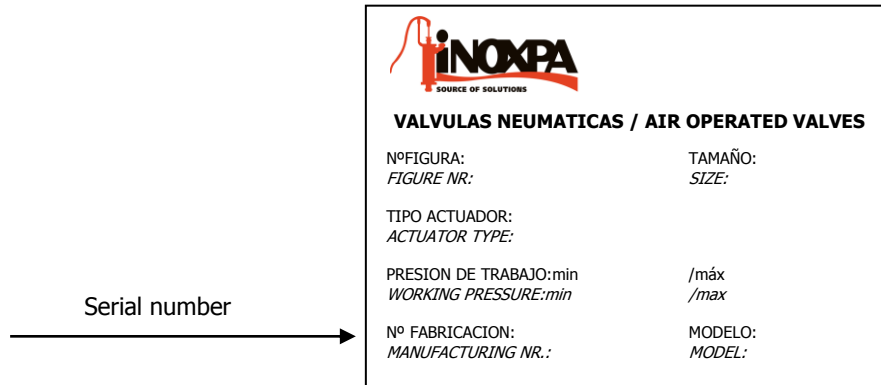

3.2. DELIVERY AND UNPACKING



INOXPA will not be responsible for the inappropriate unpacking of the valve and its components.

3.2.1. Delivery:

Check that all the parts indicated on the delivery note are correct

- Complete valve.
- Its components (if supplied).
- Delivery note.
- Instruction manual.

3.2.2. Unpacking:

- Remove all traces of packing materials from the valve or parts.
- Inspect the valve or its constituent parts for possible damage caused during transport.
- Avoid any possible damage to the valve and its components.

3.3. STORAGE

If the valve and/or diaphragm is not going to be assembled for immediate use, and are stored for later installation, they must be stored in a closed area according to the following conditions:

Temperature	from 15°C to 30°C
Relative humidity	<60%
No sunlight	store in opaque bags

Open-air storage of the equipment is **NOT** allowed.



For valves that have to be stored for a long time, the body must be disassembled as the diaphragm may become excessively deformed and/or damaged. In order to disassemble the body, see sections 7.1 and 7.2 of the chapter *Assembly and disassembly*

In order to achieve optimum behaviour of the diaphragms, do not keep them stored for more than 3 years. After this time, they may degrade and lose their properties.

3.4. IDENTIFICATION

V1 D 0 0 - 00 06 52 025 MM

SURFACE FINISH

Exterior / Interior

MM - MIRROR / MIRROR $Ra > 0.5$ (standard)
SM - SATIN / MIRROR $Ra > 0.8 / Ra > 0.5$

NOMINAL DIAMETER

003 - DN 1/8"	032 - DN 32 (DN 1 1/4")
004 - DN 4	038 - DN 1 1/2"
006 - DN 6 (DN 1/4")	040 - DN 40
008 - DN 8	050 - DN 50 (DN 2")
010 - DN 10 (DN 3/8")	063 - DN 2 1/2"
015 - DN 15 (DN 1/2")	065 - DN 65
020 - DN 20 (DN 3/4")	076 - DN 3"

DIAPHRAGM MATERIAL

52 - EPDM	78 - FPM
61 - VMO	98 - EPDM / PTFE separate

CASING MATERIAL

06 - AISI 316L

CONNECTION TYPE

0 - WELD	6 - BRIDA PN-6A - DIN 11851 SERIE 1
1 - MALE	7 - CLAMP
2 - MANDREL	8 - FLANGE PN-10C - DIN 11851 SERIES 3
3 - BUT	

CASING DESIGN

0 - DIN 11851	4 - RJT UK
1 - OD ASME	I - ISO 1127
2 - SMS FRANCE	B - ASME BPE 2007
3 - GAS DIN 259	

ACTUATION TYPE

MANUAL (V1)

0 - ST. STEEL BONNET AND HANDLE
1 - PLASTIC HANDLE ST. STEEL BONNET
2 - PLASTIC BONNET AND HANDLE

AUTOMATIC (V2)

0 - NC ST. STEEL ACT.
1 - NO ST. STEEL ACT.
2 - A/A ST. STEEL ACT.
3 - NC PLASTIC ACT.
4 - NO PLASTIC ACT.
5 - A/A PLASTIC ACT.

VALVE TYPE

D - STANDARD
N - ND L IN T
F - TANK BOTTOM
T - TANDEM
M - SAMPLING

DIAPHRAGM VALVE

V1 - MANUAL
V2 - AUTOMATIC



The buyer or user will be responsible for the assembly, installation, starting and operation of the valve.

3.5. LOCATION.

Place the valve in such a way as to facilitate inspection and checks. Leave sufficient space around the valve for appropriate inspection, separation and maintenance (See Section 3.7.1).

3.6. ASSEMBLY

Install the valve in process pipework according to good trade practice.

Once the location of the valve has been established, the pipes can be connected by either welding to the body of the valve or by means of hygienic unions. In the latter case ensure that seals are fitted and the joints fully tightened.



Before welding the bodies to the pipework, disassemble the valve to prevent damage to the diaphragm.

Excessive stress should be avoided during the assembly of the valves and special attention should be given to the following:

- Vibration which may be produced in the installation.
- Expansion of the pipes during circulation of hot liquids.
- The weight that the pipes can withstand.
- Excessive intensity of welding.

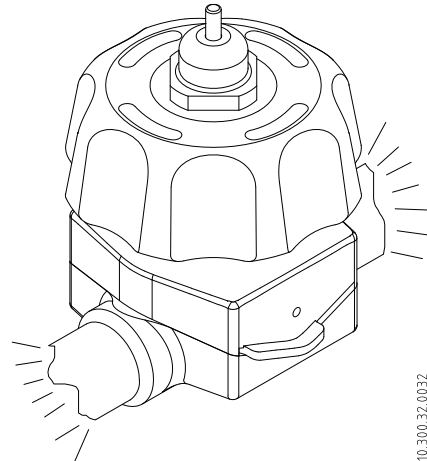

For the valve to be completely drainable, it must be placed at an angle of 2° to 3° in the line of the tube, and 20° on a perpendicular plane to the tube, as shown in the figure.



The designer and/or user is/are ultimately responsible for drainage of the process.

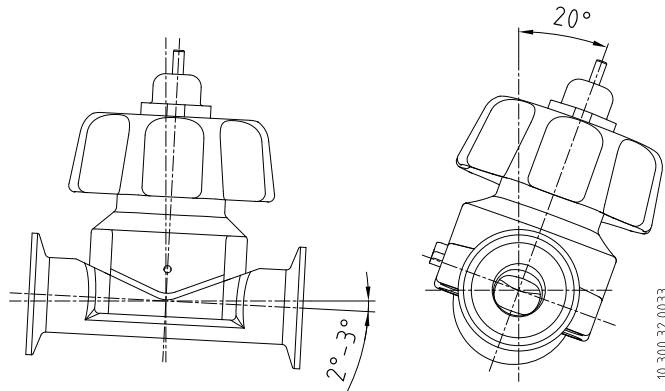

3.7. INSPECTING AND CHECKING

Check the following before use:

- Check that the screws are very tight. See tightening torque in chapter 8. *Technical Specifications*.
- Open and close the valve (applying compressed air to the actuator or moving manually if a handle is available) several times to ensure that it operates correctly. Check that the diaphragm closes completely.

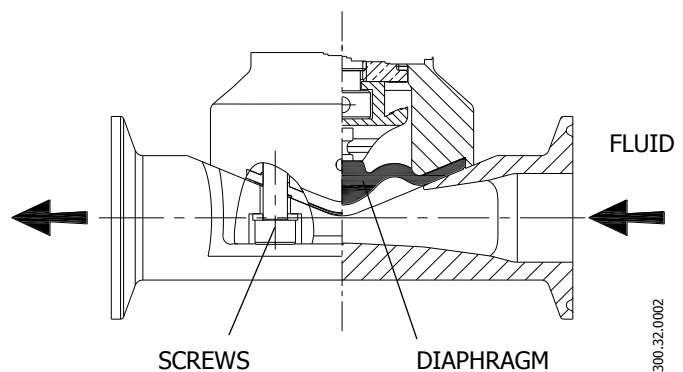

3.8. WELDING



The welding work should only be undertaken by persons qualified, trained and equipped with the necessary means to carry out this work.

Disassemble the valve before starting the welding work.

3.8.1. Weld/weld diaphragm valve.

- Disassemble the valve as indicated in section 7. *Assembly and disassembly*
- Weld the valve body to the pipework.
- When welding the valve body, it is very important to maintain the minimum distance (dimension A) enabling disassembly of the valve for later checks and replacement of valve parts (e.g. diaphragm or actuator).

DN	A
10 - 1/2"	211
25 - 1"	240
40 - 1 1/2"	308
50 - 2"	381

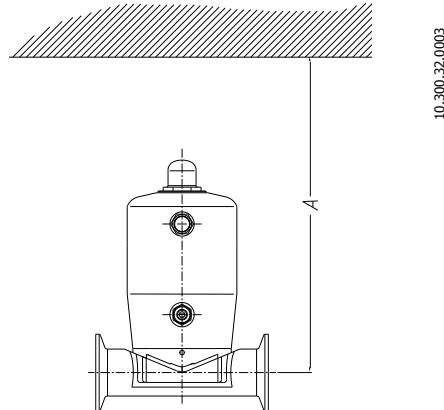

10.300.32.0003

3.9. AIR CONNECTION TO ACTUATOR

- Connect and check the air connections as required. Single Acting Spring Return or Double Acting.
- INOXPA valves are supplied with Ø6 tube connections and a silencer in Single Acting actuators.
- Bear in mind the quality of the compressed air in accordance with the specifications described in chapter 8 *Technical Specifications*.

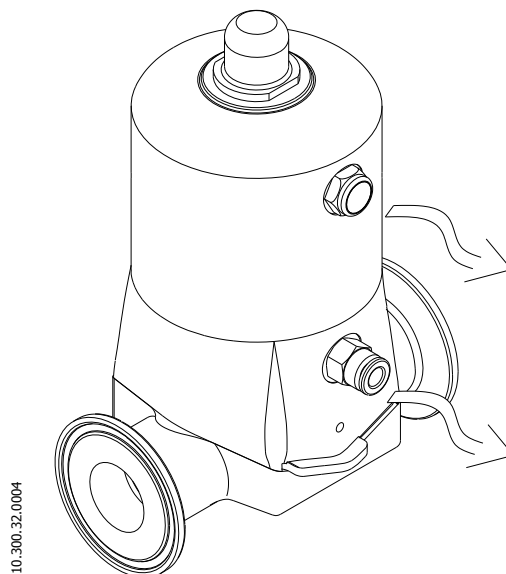

Pneumatic connections
Thread G 1/8" (BSP) for sizes from DN 1/2" to DN 1-1/2"
and thread G 1/4" (BSP) for sizes from DN 2".



The compressed-air pressure for the NO and A/A actuators (normally open and double acting) is less than in type NC (normally closed). See chapter 8. *Technical Specifications*. Excess pressure may seriously damage the diaphragm and actuator.

4. Start-up

The start-up of the valve can be carried out provided the instructions indicated in Chapter 3 – Receipt and Installation have been followed.

4.1. START-UP



Before start-up, the responsible persons should be aware of the operation of the valve and the safety instructions to be followed. This instruction manual should be available to personnel at all times.

This valve is suitable for use in food processes, cosmetics and pharmaceutical industry.

The following should be taken into consideration before starting up the valve/actuator:

- Check that the pipe and valve are completely free from any traces of weld or other foreign matter. Carry out the cleaning of the system if required.
- Verify the smooth operation of the valve. If necessary, lubricate with special grease (see Chapter 6 *Maintenance*) or soapy water.
- Check for possible leaks and check that all the pipes and connections are watertight and leak free.
- If the valve is supplied with an actuator, ensure that the actuator gives smooth operation.
- Check that the air pressure at the inlet to the actuator is as specified in Chapter 8. *Technical Specifications*
- Ensure the quality of the compressed air in accordance with the specifications described in Chapter 8 *Technical Specifications*.
- Operate the valve.

4.2. OPERATION



Do not touch the moving parts of the valve when the actuator is connected to the compressed air. Never place fingers inside the body when you have assembled a pneumatic actuator.

Danger of burns! Do not touch the valve or pipes when hot liquids are circulating or when cleaning and/or sterilization are being carried out.

Do not modify the operating parameters for which the valve has been designed without written prior authorization from INOXPA.



Visually check that the sealed area has no leaks. The valves are provided with a leak detector. The valve must be oriented so that the leak detector is visible to the plant personnel. In the case of a leak, replace the diaphragm with a new one and clean the seal area of the actuator of any fluid residue that may have remained.

Place the valve so that, if leakage occurs through the detector, the fluid cannot come into contact with personnel. This is particularly relevant in the case when hot liquids are circulating or cleaning and/or sterilisation is being carried out.

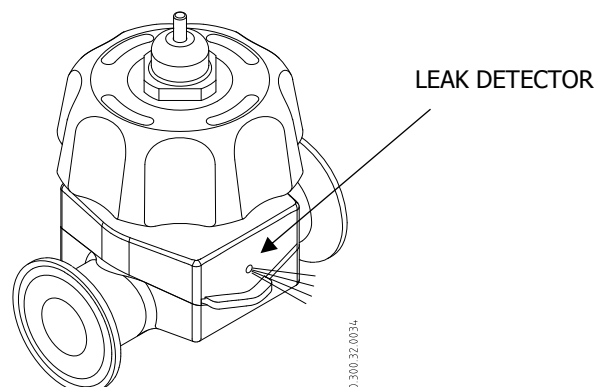

5. Operating Problems: Causes and Solutions

PROBLEM	CAUSE/EFFECT	SOLUTION
AIR LEAKING THROUGH LEAK DETECTOR	The O-ring on the shaft is worn or damaged.	<ul style="list-style-type: none"> • Replace the O-ring.
AIR LEAKING THROUGH EXIT	The O-ring of the piston is worn or damaged.	<ul style="list-style-type: none"> • Plastic actuator: replace the O-ring • St.Steel actuator: replace the actuator
FLUID LEAKING THROUGH LEAK DETECTOR	Diaphragm is damaged	<ul style="list-style-type: none"> • Replace diaphragm
EXTERNAL FLUID LEAK (BETWEEN ACTUATOR AND BODY)	Diaphragm not properly attached Screws between body and actuator are loose Diaphragm is damaged	<ul style="list-style-type: none"> • Disassemble the valve and attach correctly. • Tighten the screws • Replace diaphragm
INTERNAL FLUID LEAK (VALVE CLOSED)	Normal wear of the diaphragm.	<ul style="list-style-type: none"> • Replace the diaphragm.
	Manual valve with closed improperly adjusted	<ul style="list-style-type: none"> • Check according to chapter 7.2
	Premature wearing of the diaphragms	<ul style="list-style-type: none"> • Diaphragm worn or affected by the fluid. • Excessive pressure in the line. • Working temperature too high • Loss of watertightness (vibration). • Tight too much the valve with the manual handle.
	Overpressure	<ul style="list-style-type: none"> • Increase the compressed air pressure. • Replace the actuator with a dual-effect one.
VALVE DOES NOT OPEN/CLOSE	Diaphragm deformed. Diaphragm not properly attached. Close manual valve improperly adjusted Actuator bush in poor condition and/or jammed (dirtiness) Excessive pressure on plug	<ul style="list-style-type: none"> • Replace the diaphragm with another of different quality, if prematurely deteriorated. • Attach diaphragm correctly. • Check according to chapter 7.2 • Replace bush (clean)/ replace actuator • Reduce pipework pressure.
SURGE	The valve closes too fast.	<ul style="list-style-type: none"> • Adjust the closing speed of the actuator (with a flow regulator).

6. Maintenance

6.1. GENERAL

This valve, just like any other machine, requires maintenance. The instructions contained in this manual cover the identification and replacement of spare parts. The instructions have been prepared for maintenance personnel and for those responsible for the supply of spare parts.



Please carefully read Chapter 8. *Technical Specifications*.

All replaced material should be duly disposed of/recycled according to the directives in effect in the area.

Assembly and disassembly of the valves must only be carried out by qualified staff.

Before starting on maintenance work, ensure that the pipework is not pressurised.

6.2. MAINTENANCE

The following is recommended for appropriate maintenance:

- Regular inspection of the valve and its components.
- Keep a record of the operation of each valve, noting any incidents.
- Always have spare seals in stock.

During maintenance, pay particular attention to the danger signs indicated in this manual.



The valve and pipes should not be pressurised during maintenance.

The valve should not be hot during maintenance. Danger of burns!

6.2.1. Diaphragm maintenance.

REPLACEMENT OF DIAPHRAGMS	
Preventive maintenance	<ul style="list-style-type: none"> • Media at temperatures < 60°C replace after twelve (12) months. • Media at temperatures of 60°C to 120°C replace after three (3) months. • Exposure to steam > 100° C, but maximum 140° C The diaphragm should be inspected after approx. 50 hours exposure, e.g. after 100 sterilisation of 30 minutes. • The service life to the valve diaphragm depends on its working conditions. Decisive factors with regard to the service life are temperature and the type of process fluid. Therefore maintenance intervals can only be determined by the plant user, since they depend on the operating conditions.
Maintenance after a leak	<ul style="list-style-type: none"> • Replace at the end of the process.
Scheduled maintenance	<ul style="list-style-type: none"> • Regularly check that there are no leaks and that the valve is operating smoothly. • Keep a record of the valve. • Use statistics to plan inspections.
Lubrication	<ul style="list-style-type: none"> • During assembly, apply lubricants compatible with the diaphragm material. See the following table.

SEAL COMPONENT	LUBRICANT	Class NLGI DIN 51818
VMQ/ FPM	Klübersynth UH 1 64-2403	3
EPDM/ FPM	PARALIQ GTE 703	3

6.2.2. Storage

Storage conditions as per point 3.3 of the *Receipt and Installation* section.

6.2.3. Spare parts

To request spare parts, it is necessary to indicate the type of valve, the position and the description of the part which can be found in the *Technical Specifications* chapter 8.

6.3. CLEANING



The use of aggressive cleaning products such as caustic soda and nitric acid may cause burns to the skin.

Use rubber gloves during the cleaning process.



Always use protective goggles.

6.3.1. CIP (Clean-in-place) cleaning

If the valve is installed in a system provided with the CIP process, its disassembly will not be required.

Cleaning solutions for CIP processes.

Only use clear water (chlorine-free) to mix with the cleaning agents:

a) Alkaline solution: 1% by weight of caustic soda (NaOH) at 70°C (150°F)

1 Kg NaOH + 100 l. of water = cleaning solution

or

2.2 l. 33% NaOH + 100 l. of water = cleaning solution

b) Acid solution: 0.5% by weight of nitric acid (HNO₃) at 70°C (150°F)

or

0.7 litres HNO₃ at 53% + 100 l. of water = cleaning solution



Check the concentration of cleaning solutions; this may cause the deterioration of the seals within the valve.

To remove any remains of cleaning products, ALWAYS perform a final rinse with clean water on completion of the cleaning process.



Before beginning the disassembly and assembly work, clean the valve inside as well as outside.

6.3.2. Automatic SIP (sterilization-in-place)

The steam-sterilisation process is applied to all equipment.



DO NOT operate the equipment during the steam-sterilization process.

The parts/materials will not suffer damage provided the instructions set out in this manual are followed.

Cold liquid cannot be introduced until the equipment temperature is below 60°C (140°F).

Maximum conditions during the steam or superheated-water SIP process

- a) **Max. temperature:** 140°C / 284°F
- b) **Max. time:** 30 mins
- d) **Cooling:** Sterilised air or inert gas
- c) **Materials:** EPDM / PTFE / VMQ
FPM (not recommended)

7. Assembly and Disassembly



Proceed with caution. There is danger of personal injury.

Never disassemble the valve screws without reading the instructions thoroughly.



Assembly and disassembly of the valves / actuator must only be carried out by qualified staff.



When assembling the diaphragm it is very important to comply with the sequence of steps, as otherwise, the diaphragm may be damaged. In particular, do not fully tighten the body until the diaphragm is in the closed position. Otherwise, the diaphragm may deform and be damaged when the valve is closed.

7.1. DISASSEMBLY / ASSEMBLY OF THE MANUALLY ACTUATED VALVE

Disassembly

1. Turn the actuator handle (10) so that the valve is in the open position.
1. Unscrew the Allen screws (23) from the actuator (10).
2. Remove actuator (10) from the body (01).
3. Turn the actuator handle (10) so that the valve is in the closed position.
4. Remove the diaphragm (05) from the compressor (63).

Assembly

1. Turn the actuator handle (10) so that the valve is in the closed position.
2. Attach the diaphragm (05) to the compressor (63) so that the metal pin of the diaphragm is inserted into the groove of the compressor.
3. Place the actuator (10) in the open-valve position.
4. Connect the body (01) to the actuator (10) by screwing in the Allen screws (23) and washers (25) without fully tightening the screws (use fingers to screw in). So that the body (01) remains fixed to the actuator (10), but not yet completely tight.
5. Almost fully close the valve to deflect the diaphragm and fully tighten the screws. Apply grease to the screws before tightening, see chapter 6 *Maintenance*.
6. See the tightening torque of the screws in chapter 8 *Technical Specifications*.

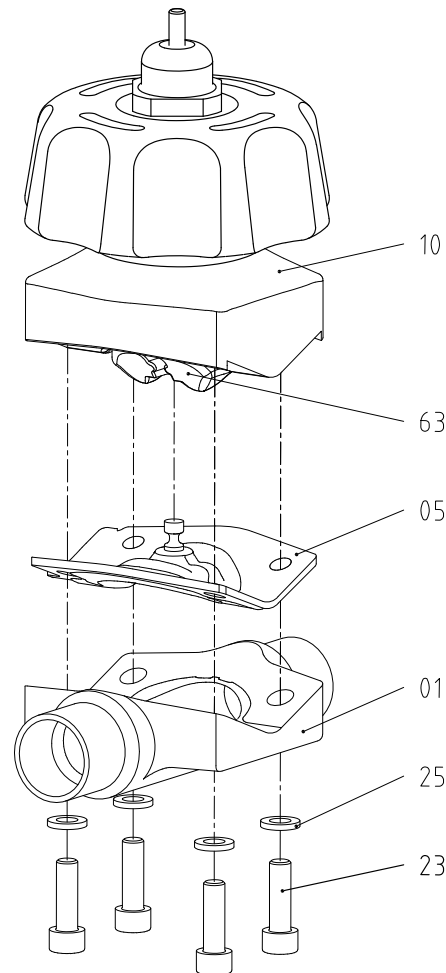

10.300.32.0035



The following tools are required to disassemble the valve.

- Allen key 3mm for size n°1
- Allen key 5mm for size n°2
- Allen key 6mm for size n°3
- Allen key 10mm for size n°4



Proceed with caution. There is danger of personal injury.

Never disassemble the valve screws without reading the instructions thoroughly.



Assembly and disassembly of the valves / actuator must only be carried out by qualified staff.



When assembling the diaphragm it is very important to comply with the sequence of steps, as otherwise, the diaphragm may be damaged. In particular, do not fully tighten the body until the diaphragm is in the closed position. Otherwise, the diaphragm may deform and be damaged when the valve is closed.

7.2. PROCEDURE FOR ADJUSTING TO CLOSURE OF THE MANUAL VALVE

The following procedure must be carried out when the valve is completely assembled (handle + diaphragm + body). Not available for size n° 4

1. Remove the cap (07) with a spanner.
2. Supply water under pressure to only one inlet of the valve (maximum pressure according to chapter 8 of *Technical Specifications*).
3. Turn the handle till the end but without forcing it too much to avoid an excessive compression of the diaphragm.
4. With the spanner, tighten the self-locking nut (26) against the lower piece.
(Or place the self-locking nut at a required height to ensure a minimum required flow).
5. Open and close the valve several times to ensure that the position of the "mechanical stopper" is correct.
6. Turn off the water supply.
7. Assemble the cap (07) with a spanner.

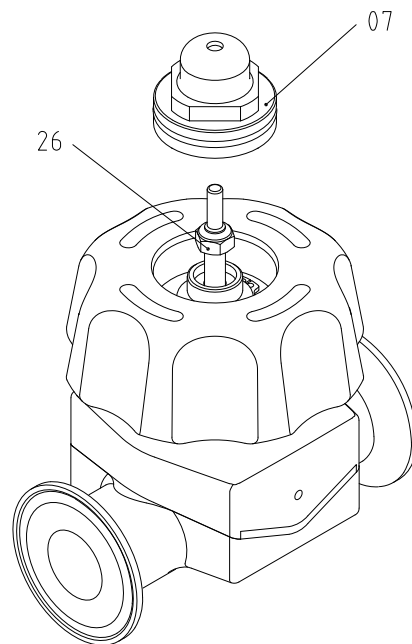

10.300.32.0038



To ensure a correct operation of the seal adjuster, it is necessary to repeat the procedure every time the maintenance tasks are carried out or when the diaphragm is changed.



The following tools are required to disassemble the valve.

- Allen key 8mm and 16mm for size n°1
- Allen key 10mm and 25mm for size n°2 / n°3



Proceed with caution. There is danger of personal injury.

Never disassemble the valve screws without reading the instructions thoroughly.



Assembly and disassembly of the valves / actuator must only be carried out by qualified staff.



When assembling the diaphragm it is very important to comply with the sequence of steps, as otherwise, the diaphragm may be damaged. In particular, do not fully tighten the body until the diaphragm is in the closed position. Otherwise, the diaphragm may deform and be damaged when the valve is closed.

7.3. DISASSEMBLY / ASSEMBLY OF THE PNEUMATICALLY ACTUATED VALVE

Disassembly

1. Apply compressed air to the actuator (10) in order to set the diaphragm (05) in the open position. (NC valve only)
2. Unscrew the Allen screws (23) of the actuator (10).
3. Remove actuator (10) from the body (01).
4. Disconnect the compressed air from the actuator (10) so that the diaphragm (05) can be detached.
5. Remove the diaphragm (05) from the compressor (63).

Assembly

1. Turn the actuator (10) so that the valve is in the closed position. (NC valves only)
2. Attach the diaphragm (05) to the compressor (63) so that the metal pin of the diaphragm is inserted into the groove of the compressor.
3. Apply compressed air to the actuator (10) in order to set the diaphragm (05) in the open position. (NC valve only)
4. Connect the body (01) to the actuator (10) by screwing in the Allen screws (23) and washers (25) without fully tightening the screws (use fingers to screw in). So that the body (01) remains fixed to the actuator (10), but not yet completely tight.
5. Disconnect the compressed air from the actuator (10) so that the diaphragm (05) is placed in the **closed position**, and the compressor (63) tightens the diaphragm against the body (01).
6. **Tighten the screws up to the specified tightening torque.** See the tightening torque of the screws in chapter 8 *Technical Specifications*. Apply grease to the screws before tightening see chapter 6 *Maintenance*.

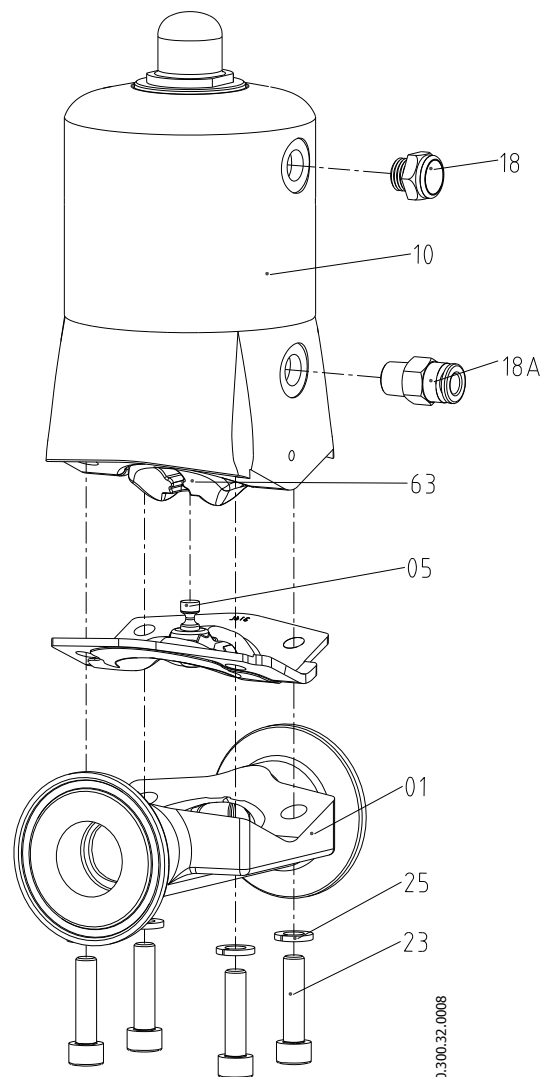

10.300.32.0008



The following tools are required to disassemble the valve.

- Allen key 3mm for size n°1
- Allen key 5mm for size n°2
- Allen key 6mm for size n°3
- Allen key 10mm for size n°4

8. Technical Specifications

VALVE GENERAL DATA

Maximum working pressure (bar / PSI)

DN	INOX Manual Operation		Plastic Manual Operation		SA Pneumatic Operation		DA Pneumatic Operation	
	EPDM FPM VMQ	PTFE	EPDM FPM VMQ	PTFE	EPDM FPM VMQ	PTFE	EPDM FPM VMQ	PTFE
DN 6 to 10 / DN ¼" to DN 5/8"	10 bar / 145 PSI	10 bar / 145 PSI	8 bar / 116 PSI	8 bar / 116 PSI	8 bar / 116 PSI	8 bar / 116 PSI	10 bar / 145 PSI	10 bar / 145 PSI
DN 15 to 25 / DN ¾" to 1"	10 bar / 145 PSI	10 bar / 145 PSI	8 bar / 116 PSI	8 bar / 116 PSI	6 bar / 87 PSI	6 bar / 87 PSI	10 bar / 145 PSI	10 bar / 145 PSI
DN 32 to 40 / DN 1 ½"	10 bar / 145 PSI	10 bar / 145 PSI	8 bar / 116 PSI	8 bar / 116 PSI	6 bar / 87 PSI	6 bar / 87 PSI	10 bar / 145 PSI	10 bar / 145 PSI
DN 50 / DN 2"	6 bar / 87 PSI	4 bar / 58 PSI	-	-	4 bar / 58 PSI	4 bar / 58 PSI	4 bar / 58 PSI	4 bar / 58 PSI
- Working pressures determined from the hydrostatic pressure applied on one side of the closed valve. For working pressures applied on both sides, consult INOXPA.								
Minimum working pressure			Vacuum (may vary according to model; consult INOXPA)					
Pipework temperature for actuators For autoclavable actuators consult INOXPA.			Stainless-steel valve			Plastic valve		
			-20°C (-4°F) - +140°C (284°F)			+5°C (41°F) - +80°C (176°F) for actuation of PP+30 % GF		
Compressed air pressure			<ul style="list-style-type: none"> - NC 5-7 bar (72 - 101 PSI) actuator – recommended pressure 6 bar (97 PSI) - NO and A/A max. 4 bar (58 PSI) actuator – recommended pressure 3 bar (43 PSI) 					
Compressed air quality			In accordance with DIN/ISO 8573.1 <ul style="list-style-type: none"> o <u>Solid-particle content</u>: Class-3 quality / Max. particle size 5 microns / Max. particle density 5 mg/m³ o <u>Water content</u>: Class-4 quality / max. condensation point +2°C. If the valve is operating at high altitude or low ambient temperature, the condensation point must be adapted accordingly. o <u>Oil content</u>: Class-5 quality, preferably oil-free / max. 25 mg oil per 1 m³ air. 					
Compressed air connection			G1/8" (BSP) for DN 6 to DN 40, and G1/4" (BSP) for larger sizes					
Compressed air consumption (litres of air /cycle).			SIZE:		NC (Single Effect)		A/A (Double effect)	
			DN 6 to 10 / DN ¼" to DN 5/8"		0,22		0,38	
			DN 15 to 25 / DN ¾" to 1"		0,73		1,54	
			DN 32 to 40 / DN 1 ½"		1,35		3,7	
			DN 50 / DN 2"		3,81		7,3	

VALVE MATERIALS	
Parts in contact with the product	AISI 316L
Other steel parts	AISI 304
Plastic parts	PP+ 30% GF / PC / POM
Gaskets in contact with the fluid	EPDM (Standard) - VMQ – FPM – EPDM/PTFE separate
Surface finish in steel parts	In contact with the fluid: Ra ≤ 0.5 µm (Standard) External surfaces: mirror finish (Standard), satin finish, shot-blasted.
Type of connections	Clamp, DIN 11851, Weld, BS-RJT, SMS, Flanges.

DIAPHRAGM FEATURES				
	EPDM	PTFE/EPDM	FPM	VMQ
Type	EAF 70	-	FBF 70	QPF 70
Colour	Black	White	Grey	Light grey
Hardness	70	-	70	70
Max.working temperature	90°C (194°F)	90°C (194°F)	120°C (248°F)	120°C (248°F)
Min. Working temperature	- 20°C (-4°F)	- 20°C (-4°F)	- 10°C (14°F)	- 20°C (-4°F)
Sterilization temperature (1)	140°C/30 min	140°C/30 min	No recomendado	140°C/30 min
Certificate	FDA / USP	FDA	FDA / USP	FDA / USP

(1) Temperature allowed without actuate the valve.

Tools/assembly tightening torque

Valve size	DN 6 to 10 / DN 1/4" to DN 5/8"	DN 15 to 25 / DN 3/4" to 1"	DN 32 to 40 / DN 1 1/2"	DN 50 / DN 2"
DIN 911 spanner	3	5	6	10
Max. tightening torque	2 Nm	6 Nm	11 Nm	34 Nm



Excessive tightening torque may damage the actuator. Use a torque wrench to control the torque. When tightening the screws, use grease to reduce friction. Use grease of the type specified in chapter 6 *Maintenance*.

		VALVE WEIGHT [kg]		
		MANUAL		PNEUMATIC
SIZE	DN	ST.STEEL	PLASTIC	ST.STEEL
Nº1	6	0,6	0,3	1,2
	8			
	10			
	15			
Nº2	20	1,9	0,9	2,5
	25			
Nº3	40	3,2	1,8	6,7
Nº4	50	6,9	-	14,9

(Weight valid only for welding connections and pneumatic actuators NC)

8.1. MANUALLY ACTUATED VALVE DIMENSIONS

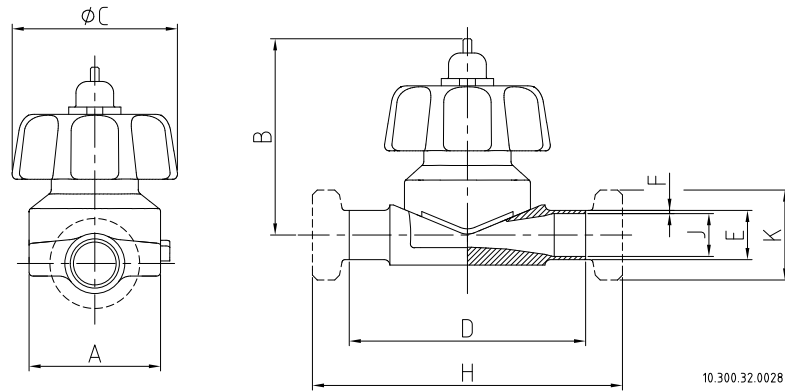

Size	DN	A	B	C	Weld			OD Clamp			SMS male		
					D	E	F	H	J	K	H	J	K
Nº1	1/4"	38	68	60	86	6,4	1,65	86	3,1	25,4	---	---	---
	3/8"					9,5			6,2		---	---	---
	1/2"					12,7			9,4		---	---	---
	5/8"					15,9			12,6		---	---	---
Nº2	3/4"	68	105	89	122	19	1,65	114	15,8	25,4	---	---	---
	1"					25,4			22,1		50,5	160	22,5
Nº3	1 1/2"	95	134	89	160	38,1	1,65	140	34,8	50,5	206	35,5	60
Nº4	2"	130	160	134	191	50,8	1,65	159	47,5	64	237	48,5	70

Size	DN	A	B	C	Weld			DIN Clamp			DIN male		
					D	E	F	H	J	K	H	J	K
Nº1	6	38	68	60	86	8	1	86	6,2	25,4	---	---	---
	8					10			8		---	---	---
	10					12			1,5		10	34	120
Nº2	15	68	105	89	122	19	1,6	158	16	34	156	16	34
	20					23			20		160	20	44
	25					29			2		114	26	50,5
Nº3	32	95	134	89	160	35	1,5	140	32	50,5	204	32	58
	40					41			182			38	38
Nº4	50	130	160	134	191	53	1,5	159	50	64	237	50	78

8.2. STAINLESS-STEEL PNEUMATICALLY ACTUATED VALVE DIMENSIONS

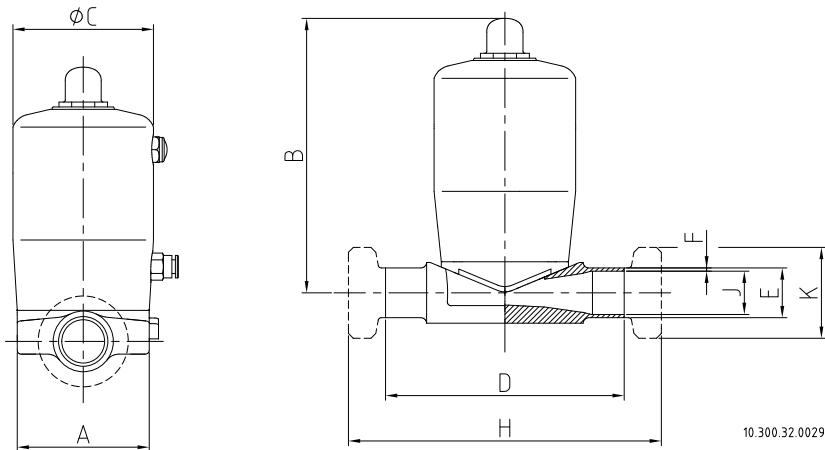

Size	DN	A	B	C	Weld			OD Clamp			SMS Male		
					D	E	F	H	J	K	H	J	K
Nº1	1/4"	38	111	60	86	6,4	1,65	86	3,1	25,4	---	---	---
	3/8"					9,5			6,2		---	---	---
	1/2"					12,7			9,4		---	---	---
	5/8"					15,9			12,6		---	---	---
Nº2	3/4"	68	143	89	122	19	1,65	114	15,8	25,4	---	---	---
	1"					25,4			22,1		50,5	160	22,5
Nº3	1 1/2"	95	211	108	160	38,1	1,65	140	34,8	50,5	206	35,5	60
Nº4	2"	130	287	134	191	50,8	1,65	159	47,5	64	237	48,5	70

Size	DN	A	B	C	Weld			DIN Clamp			DIN male		
					D	E	F	H	J	K	H	J	K
Nº1	6	38	111	57	86	8	1	86	6,2	25,4	---	---	---
	8					10			8		---	---	---
	10					12			1,5		10	34	120
Nº2	15	68	143	72	122	19	1,6	158	16	34	156	16	34
	20					23			20		160	20	44
	25					29			2		114	26	50,5
Nº3	32	95	211	108	160	35	1,5	140	32	50,5	204	32	58
	40					41			38			38	65
Nº4	50	130	287	135	191	53	1,5	159	50	64	237	50	78

8.3. SECTION AND PARTS LIST

8.3.1. Section and parts list for MANUALLY ACTUATED VALVE N°1, N°2 & N°3

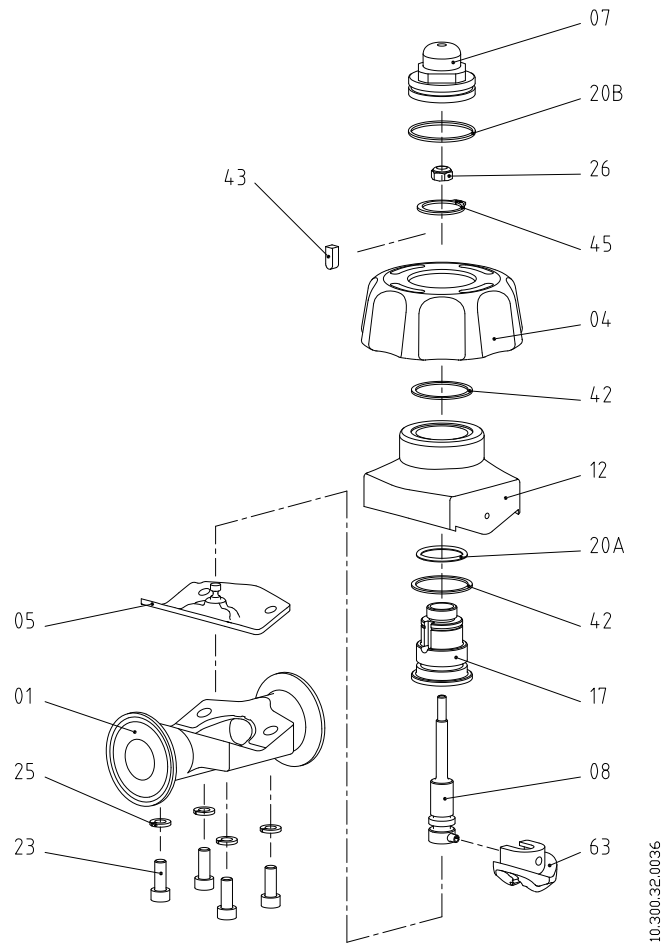

POSICIÓN	DESIGNACIÓN	MATERIAL	CANTIDAD
01	Body	CF 3M	1
04	Handle	CF 8 / PP+30GF	1
05	Diaphragm	-	1
07	Cover	POM	1
08	Shaft	AISI 304	1
12	Bonnet	CF 3M / PP+30GF	1
17	Bushing	Brass	1
20A	O-ring	NBR	1
20B	O-ring	NBR	1
23	DIN 912 Allen screw	A2	4
25	WASHER DIN 127	A2	4
26	Self-locking nut	A2	1
42	Washer	PTFE+GF	2
43	Key	AISI 304	1
45	DIN 471 elastic ring	A2	1
63	Compressor	CF 3M	1

8.3.2. Section and parts list for MANUALLY ACTUATED VALVE N°4 (Without stroke limiter)

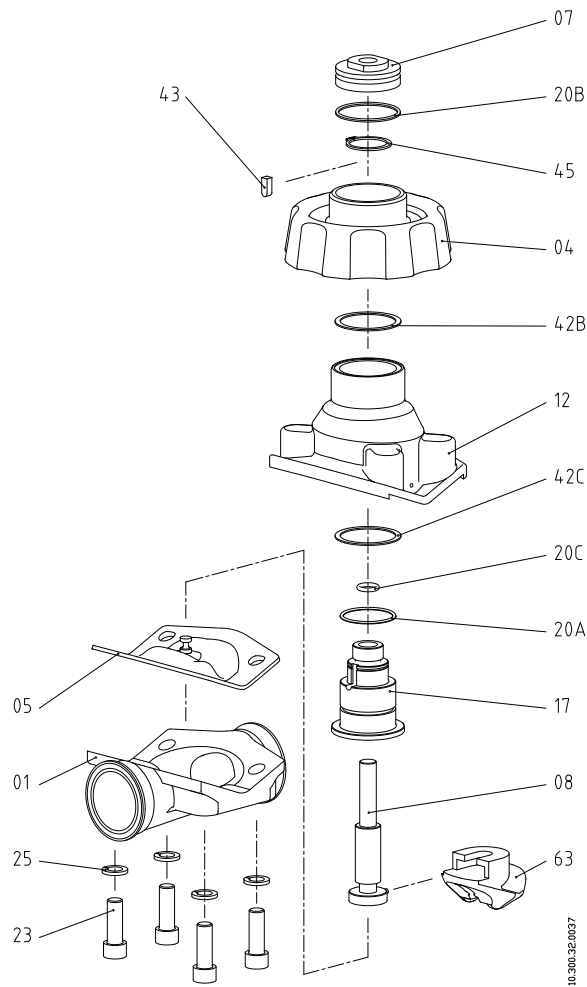

POSICIÓN	DESIGNACIÓN	MATERIAL	CANTIDAD
01	Body	CF 3M	1
04	Handle	CF 8	1
05	Diaphragm	-	1
07	Cover	POM	1
08	Shaft	AISI 304	1
12	Bonnet	CF 3M	1
17	Bushing	Brass	1
20A	O-ring	NBR	1
20B	O-ring	NBR	1
20C	O-ring	NBR	1
23	DIN 912 Allen screw	A2	4
25	WASHER DIN 127	A2	4
42B	Bottom washer	PTFE+GF	1
42C	Top washer	PTFE+GF	1
43	Key	AISI 304	1
45	DIN 471 elastic ring	A2	1
63	Compressor	CF 3M	1

8.3.3. Section and parts list for STAINLESS-STEEL PNEUMATICALLY ACTUATED VALVE

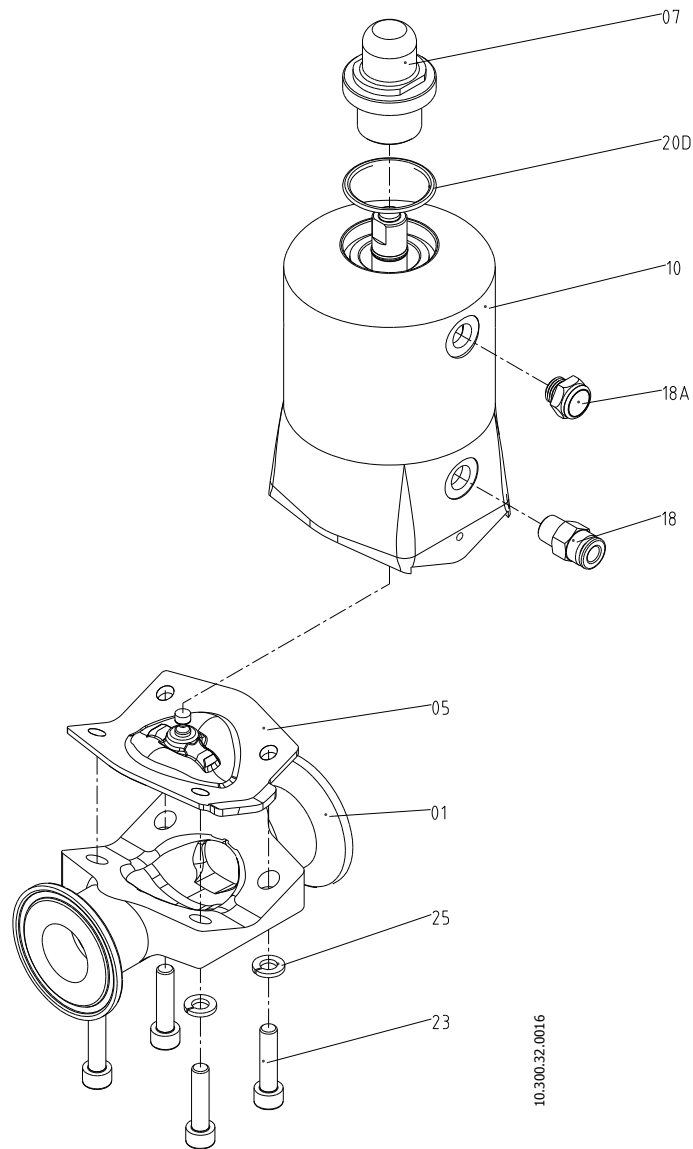

POSICIÓN	DESIGNACIÓN	MATERIAL	CANTIDAD
01	Casing	CF 3M	1
05	Diaphragm	-	1
07	Indicator Glass	PC	1
10	Actuator	AISI 304	1
18	Straight connector R 1/8"	-	1
18A	Silencer R 1/8"	-	1
20D	O-ring	NBR	1
23	DIN 912 Allen screw	A2	4
25	WASHER DIN 127	A2	4

NOTES

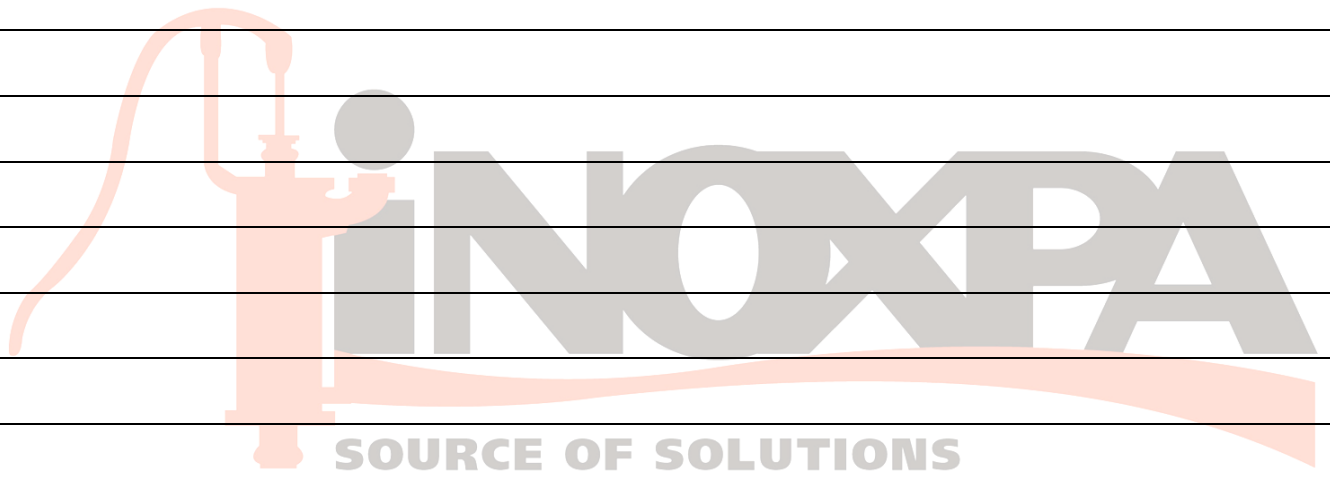

NOTES

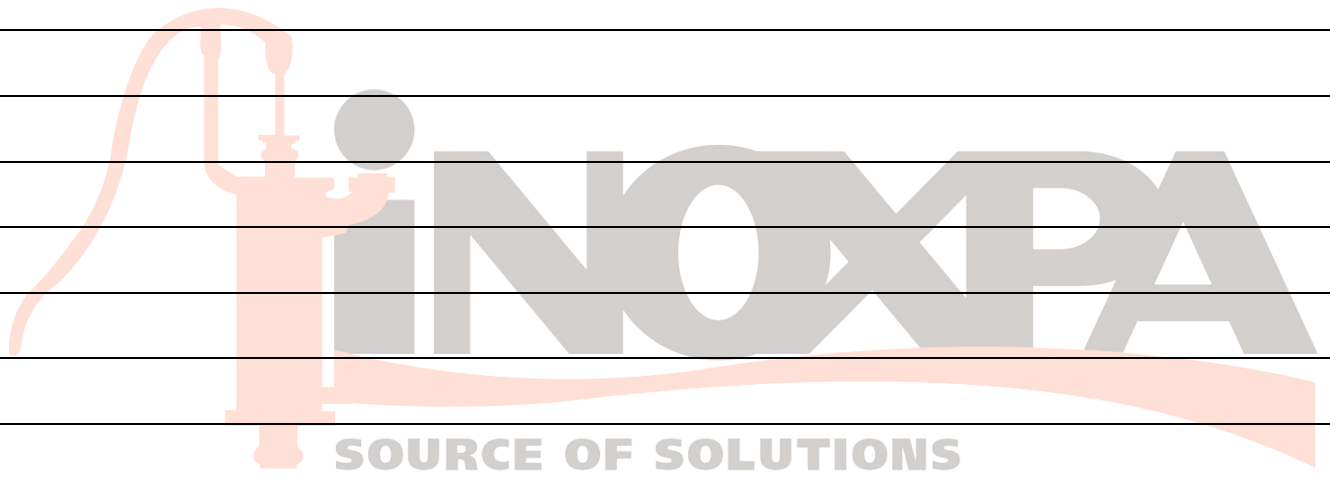



INOXPA, S.A.
BANYOLES
Tel. +34 972 575 200
inoxpa@inoxpa.com

DELEGACIÓN NORDESTE
BARCELONA
Tel. +34 937 297 280
inoxpa.nordeste@inoxpa.com

DELEGACIÓN CENTRO
MADRID
Tel. +34 918 716 084
inoxpa.centro@inoxpa.com

DELEGACIÓN LEVANTE
VALENCIA
Tel. +34 963 170 101
inoxpa.levante@inoxpa.com

DELEGACIÓN SUR
CADIZ
Tel. +34 956 140 193
inoxpa.sur@inoxpa.com

**SUMINISTROS TECNICOS
ALIMENTARIOS, S.L.**
VIZCAYA
Tel. +34 944 572 058
sta@inoxpa.com

DELEGACIÓN VALLADOLID
Tel. +34 983 403 197
sta.valladolid@inoxpa.com

**DELEGACIÓN GALICIA,
ASTURIAS y LEÓN**
Tel. +34 638 334 359
sta@inoxpa.com

**INOXPA SOLUTIONS
FRANCE SAS**
LYON
Tel. +33 474627100
inoxpa.fr@inoxpa.com

PARIS
Tel. +33 130289100
isf@inoxpa.com

S.T.A. PORTUGUESA LDA
ALGERIZ
Tel. +351 256472722
comercial.pt@inoxpa.com

**IMPROVED SOLUTIONS
PORTUGAL LDA**
VALE DE CAMBRA
Tel. +351 256 472 138
isp.pt@inoxpa.com

INOXPA SKANDINAVIEN A/S
DENMARK
Tel. +45 76286900
inoxpa.dk@inoxpa.com

SWEDEN
Tel. 031-336 05 60
inoxpa.se@inoxpa.com

INOXPA ITALIA, S.R.L.
VENEZIA
Tel. +39 041 - 411236
inoxpa.it@inoxpa.com

INOXPA UK LTD
KENT
Tel. 01737 378060
inoxpa-uk@inoxpa.com

INOXPA Solutions Moldova
CHISINAU
Tel. +373 (69)102 624
info@gmp-moldova.com

INOXRUS
САНКТ-ПЕТЕРБУРГ
Тел. +7 812 622 16 26
spb@inoxpa.com

МОСКВА
Тел. +7 495 120 26 17
moscow@inoxpa.com

STARINOX
МОСКВА
Тел. + 7 495 215 02 42
info@starinox.ru

INOXPA UKRAINE
КИЕВ
Тел. +38 044 536 09 57
kiev@inoxpa.com

INOXPA COLOMBIA SAS
BOGOTÁ
Pbx 57-1-7427577
inoxpa.colombia@inoxpa.com

INOXPA USA, INC
CALIFORNIA
Tel. +1 707 585 3900
inoxpa.us@inoxpa.com

INOXPA AUSTRALIA PTY, LTD
MORNINGTON
Tel. +61 (3) 5976 8881
inoxpa.au@inoxpa.com

INOXPA SOUTH AFRICA
GAUTENG
Tel. +27 (0)11 794-5223
sales@inoxpa.com

INOXPA ALGERIE S.A.R.L.
ALGER
Tel. +213 (0) 23 833 320
inoxpalgerie@inoxpa.com

INOXPA EGYPT
CAIRO
Tel. +2 0111 489 8989
inoxpa.eg@inoxpa.com

**INOXPA SPECIAL PROCESSING
EQUIPMENT (JIAXING), CO., LTD.**
JIAXING, CHINA
Tel.: 00 86 573 83570035
inoxpa.cn@inoxpa.com

INOXPA INDIA PRIVATE LIMITED
MAHARASHTRA
Tel. +91 020-64705492
inoxpa.in@inoxpa.com

INOXPA MIDDLE EAST
DUBAI, UAE
Tel. +971 4 333 5388
sales.ae@inoxpa.com

In addition to our branch offices, INOXPA operates with an independent distributor network which encompasses a total of more than 50 countries throughout the world. For more information consult our web page: www.inoxpa.com
This information is a guideline only. We reserve the right to modify any material or characteristic without prior notice.